

DESCRIPTION: HIGH DENSITY - MACHINED CONTACTS - RIGHT ANGLE

MATERIALS AND FINISH:

SHELL: STEEL MATERIAL, NICKEL FINISH
 INSULATOR: PA6T=260°C, UL 94V-0 RATED, BLACK
 CONTACT MATERIAL: BRASS
 CONTACT FINISH: SELECTIVE GOLD FINISHED

ELECTRICAL:

CONTACT CURRENT RATING: 5 AMPS
 CONTACT RESISTANCE: 30 Milliohms Max.
 DIELECTRIC WITHSTANDING VOLTAGE: 1,00VAC Min.
 INSULATION RESISTANCE: 5,000 Megohms Min.
 TEMPERATURE RATING: -55° ~ +105° C

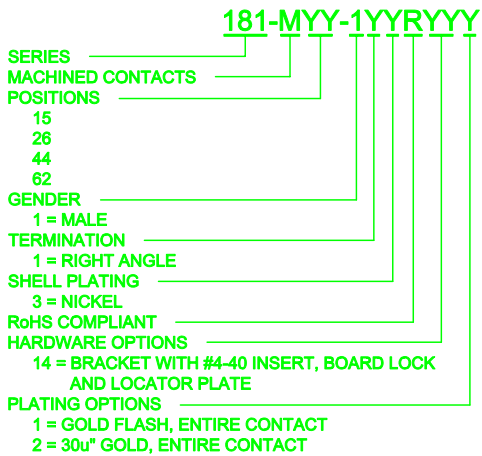
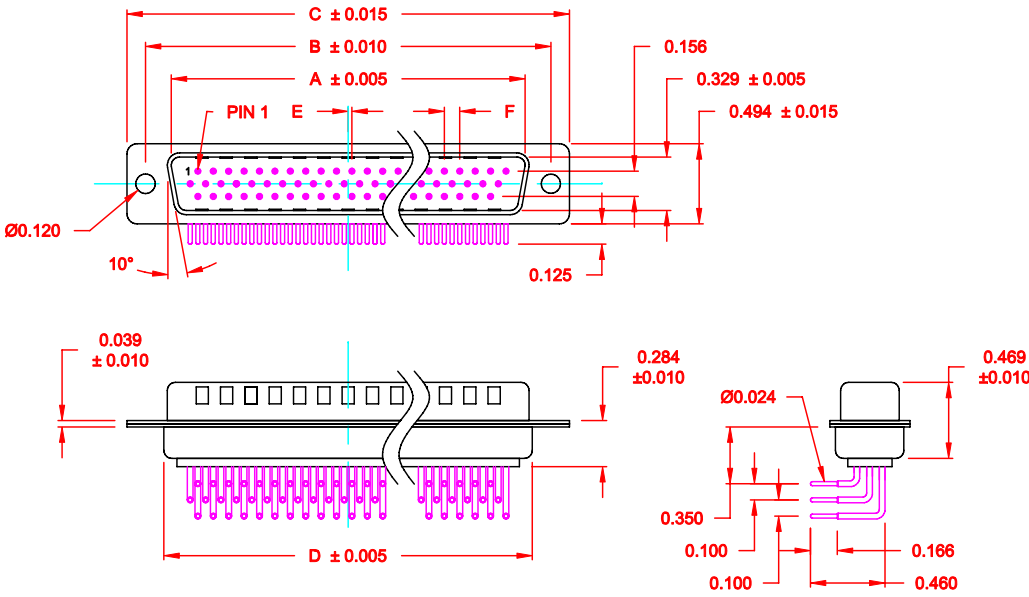

DIMENSIONS (IN.)						
No. OF PINS	A	B	C	D	E	F
15	0.666	0.984	1.213	0.759	0.010	0.090
25	0.994	1.312	1.541	1.083	0.020	0.090
44	1.534	1.852	2.088	1.625	0.020	0.090
62	2.182	2.500	2.729	2.272	0.023	0.094

DO NOT SCALE FROM DRAWING

	THESE DRAWINGS AND SPECIFICATIONS ARE THE PROPERTY OF NorComp AND SHALL NOT BE REPRODUCED, COPIED OR USED AS THE BASIS FOR THE MANUFACTURE OF SALE OF APPARATUS WITHOUT WRITTEN PERMISSION.		DRAWN: C. SMITH CHECKED:	DATE: 03-16-07 DATE:
	<h1>NorComp</h1>		SCALE: 1:1 DWG NO. 181-MYY-1YYRYYY	SHEET 1 OF 4 REV 7

RoHS COMPLIANT

DESCRIPTION: HIGH DENSITY - MACHINED CONTACTS - RIGHT ANGLE

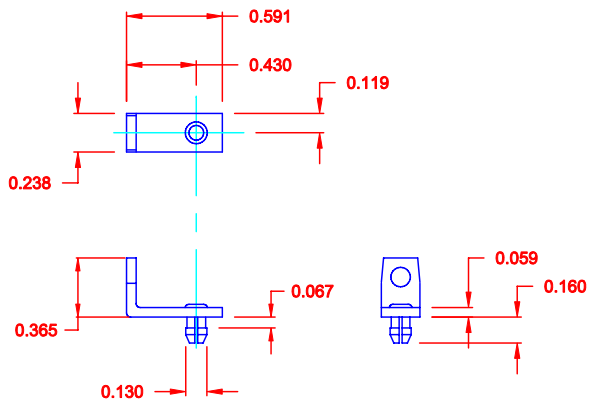

MOUNTING BRACKET WITH BOARD LOCK

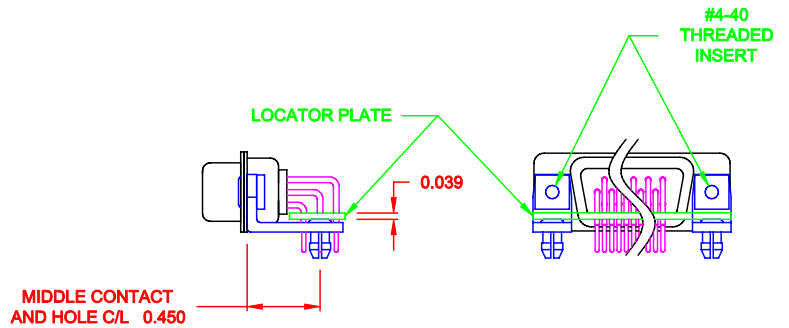

BRACKETS MOUNTED ON CONNECTOR WITH LOCATOR PLATE

FOR CLARITY HIDDEN LINES NOT SHOWN

MATERIAL: COLD ROLLED STEEL

PLATING: CLEAR ZINC

	THESE DRAWINGS AND SPECIFICATIONS ARE THE PROPERTY OF NorComp AND SHALL NOT BE REPRODUCED, COPIED OR USED AS THE BASIS FOR THE MANUFACTURE OF SALE OF APPARATUS WITHOUT WRITTEN PERMISSION.		DRAWN: PAM JENKINS	DATE: 11-28-05
			CHECKED:	DATE:
NorComp		SCALE: 1 : 1	SHEET 2	OF 4
		DWG NO. 181-MYY-1YYRYYY		

DESCRIPTION: HIGH DENSITY LOCATOR PLATES - 15, 26, 44, 62 & 78

NOTE: MALE LOCATOR PLATE SHOWN
FLIP FOR FEMALE

MATERIAL: INSULATION PAPER
0.039" THICK

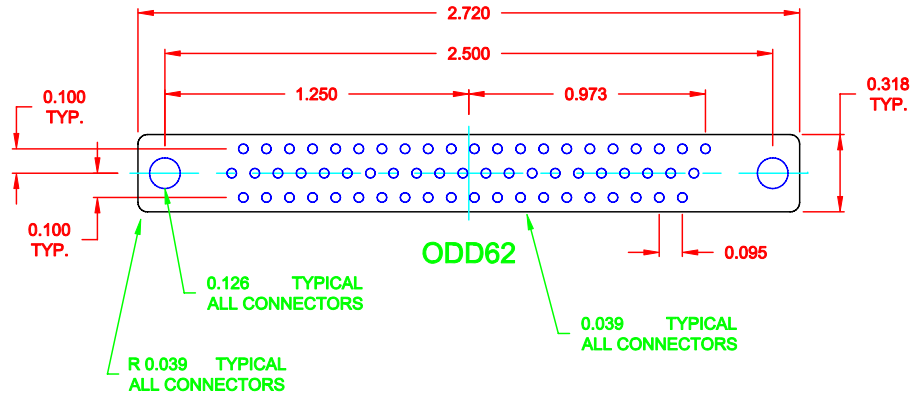
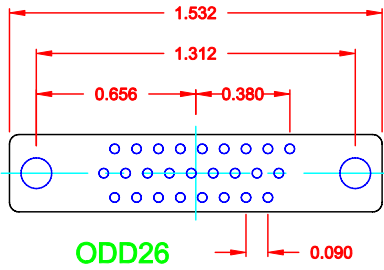
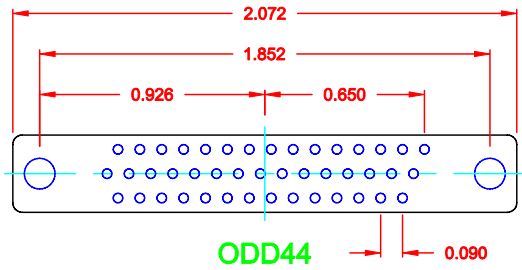
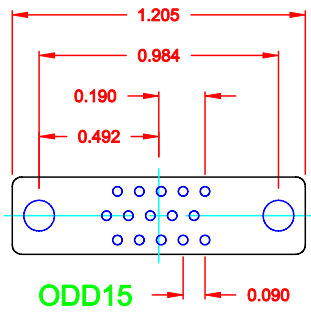

DO NOT SCALE FROM DRAWING

RoHS COMPLIANT

	THESE DRAWINGS AND SPECIFICATIONS ARE THE PROPERTY OF NorComp AND SHALL NOT BE REPRODUCED, COPIED OR USED AS THE BASIS FOR THE MANUFACTURE OF SALE OF APPARATUS WITHOUT WRITTEN PERMISSION.		DRAWN: C. SMITH	DATE: 02-18-08
			CHECKED:	DATE:
NorComp		SCALE: 1.5 : 1	SHEET 3	OF 4
		DWG NO. 181-MYY-1YYRYYY		

DESCRIPTION: HIGH DENSITY - MACHINED CONTACTS - RIGHT ANGLE

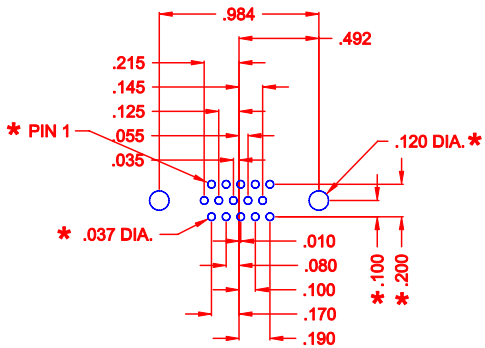

15 POSITION

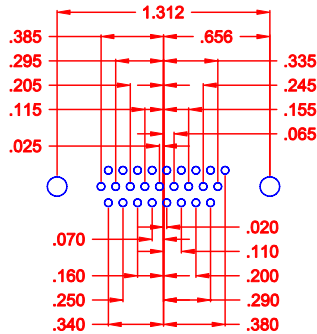

26 POSITION

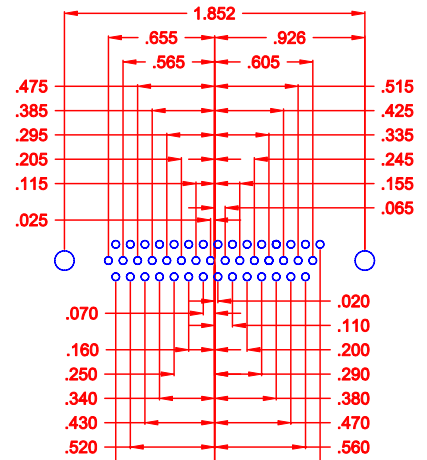

44 POSITION

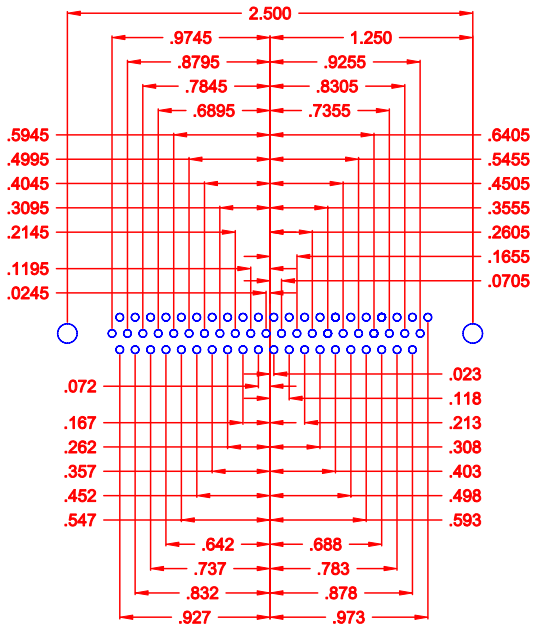

62 POSITION

* TYP. ON ALL SIZES

DO NOT SCALE FROM DRAWING

	THESE DRAWINGS AND SPECIFICATIONS ARE THE PROPERTY OF NorComp AND SHALL NOT BE REPRODUCED, COPIED OR USED AS THE BASIS FOR THE MANUFACTURE OF SALE OF APPARATUS WITHOUT WRITTEN PERMISSION.		DRAWN: C. SMITH CHECKED:	DATE: 03-16-07 DATE:
	NorComp		SCALE: 1 : 1 DWG NO. 181-MYY-1YYRYYY	SHEET 4 OF 4 REV 7