

DESCRIPTION: FEMALE - 0.283 RIGHT ANGLE / MACHINED - ECONOMY

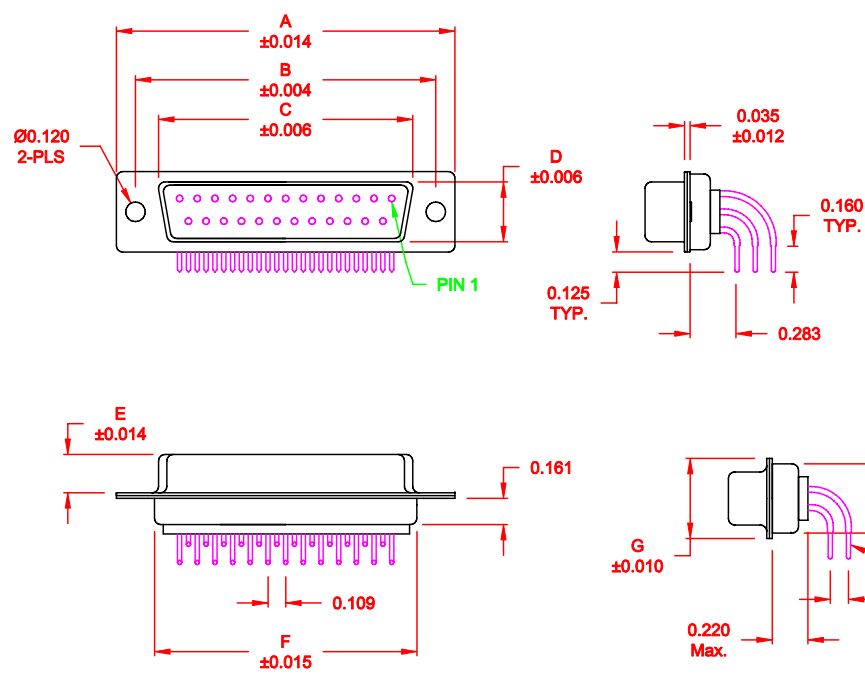

No. OF PINS	DIMENSIONS							
	A	B	C	D	E	F	G	H
9	1.213	0.984	0.642	0.311	0.236	0.756	0.496	0.427
	30.80	24.99	16.30	7.90	5.99	19.20	12.60	10.85
15	1.541	1.312	0.970	0.311	0.236	1.091	0.496	0.427
	39.15	33.32	24.65	7.90	5.99	27.70	12.60	10.85
25	2.087	1.852	1.512	0.311	0.236	1.618	0.496	0.427
	53.00	47.04	38.40	7.90	5.99	41.10	12.60	10.85
37	2.728	2.500	2.157	0.311	0.236	2.256	0.496	0.427
	69.30	63.50	54.80	7.90	5.99	57.30	12.60	10.85
50	2.638	2.406	2.055	0.429	0.240	2.169	0.602	0.527
	67.00	61.11	52.20	10.90	6.10	55.10	15.30	13.39

173-EYY-21YRY1

- SERIES
- POSITIONS
- E09
- E15
- E25
- E37
- E50
- GENDER
- 2 = FEMALE
- TERMINATION
- 1 = PC MOUNTING
- SHELL PLATING
- 3 = NICKEL
- RoHS COMPLIANT
- HARDWARE OPTIONS
- 00 = NO HARDWARE
- 14 = SHORT BRACKET WITH 4-40 SCREW LOCK
- 24 = SHORT BRACKET WITH 4-40 SCREW
- PLATING OPTIONS
- 1 = GOLD FLASH
- 2 = 30MICRO-INCH GOLD

**MATERIAL:**

- SHELL: STEEL, NICKEL PLATED
- INSULATOR: UL 94V-O RATED, WHITE PA6T
- PROCESS TEMP.: 260° PROCESS TEMPERATURE
- CONTACT: BRASS

**ELECTRICAL:**

- CURRENT RATING: 5 AMPS
- CONTACT RESISTANCE: 15 mOhms Max.
- INSULATION RESISTANCE: 1,000 MOhms min.
- VOLTAGE: 500VAC FOR 1 MINUTE
- TEMPERATURE: -50° C TO 100° C

DO NOT SCALE FROM DRAWING

RoHS COMPLIANT

	THESE DRAWINGS AND SPECIFICATIONS ARE THE PROPERTY OF NorComp AND SHALL NOT BE REPRODUCED, COPIED OR USED AS THE BASIS FOR THE MANUFACTURE OF SALE OF APPARATUS WITHOUT WRITTEN PERMISSION.		DRAWN: WAYNE ROBBINS	DATE: 11-28-05
			CHECKED:	DATE:
<b>NorComp</b>		SCALE: 1 : 1	SHEET 1 OF 3	REV 5
		DWG NO. 173-EYY-21YRY1		

DESCRIPTION: PCB LAYOUT - MALE & FEMALE

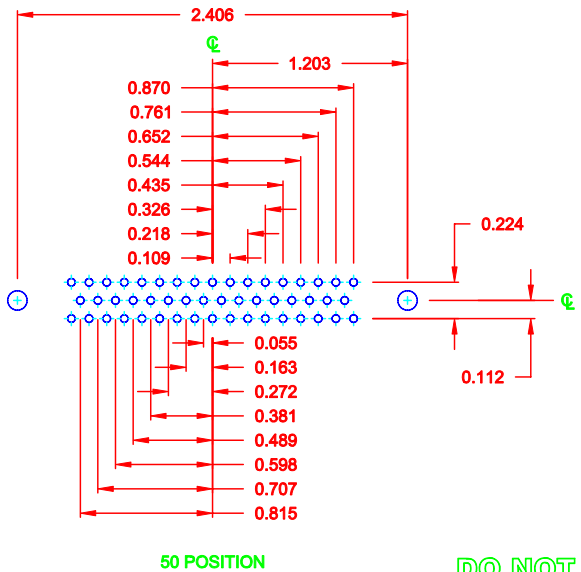
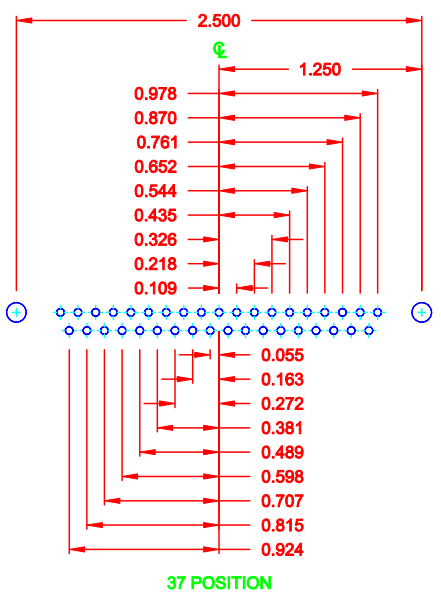
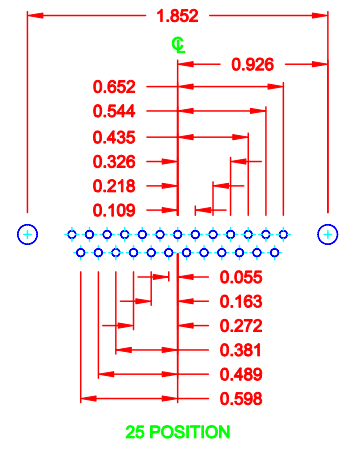
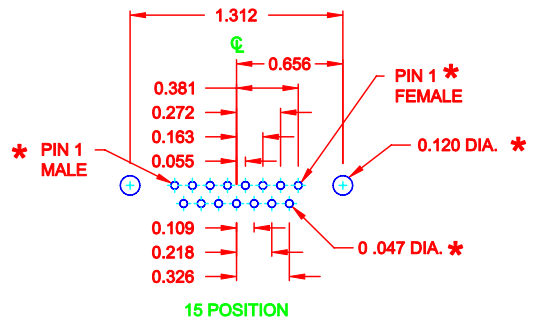
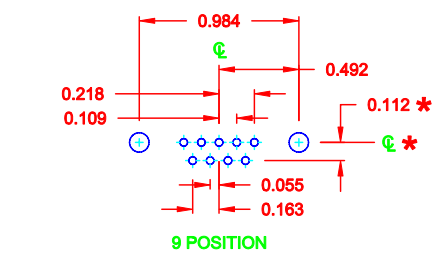

\* TYP. ON ALL SIZES  
UNLESS NOTED OTHERWISE

DO NOT SCALE FROM DRAWING

	THESE DRAWINGS AND SPECIFICATIONS ARE THE PROPERTY OF NorComp AND SHALL NOT BE REPRODUCED, COPIED OR USED AS THE BASIS FOR THE MANUFACTURE OF SALE OF APPARATUS WITHOUT WRITTEN PERMISSION.		DRAWN: <b>C. SMITH</b>	DATE: <b>03-08-06</b>
	NorComp			CHECKED:
SCALE: <b>FULL</b>				SHEET <b>2</b> OF <b>3</b>
DWG NO. <b>173-EYY-21YRY1</b>				

DESCRIPTION: CLINCH NUT HARDWARE

**HARDWARE OPTIONS**

REPLACE -YY IN LAST 3 DIGITS WITH OPTION CHOSEN

**173/174 SERIES**

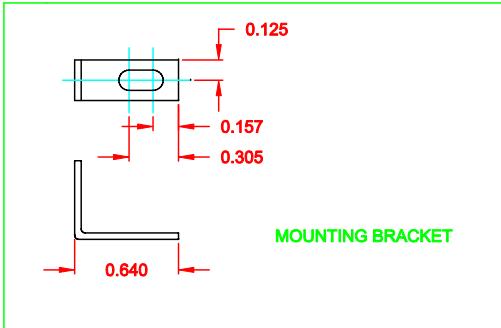

**173 / 174 SERIES**

14Y = SHORT BRACKET & 4-40 FEMALE HEX SOCKET  
 24Y = SHORT BRACKET & 4-40 SCREW

**175/176 SERIES**

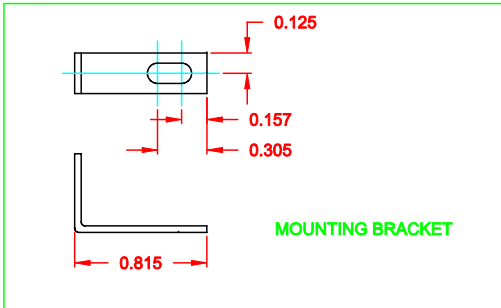

**176 / 176 SERIES**

15Y = LONG BRACKET & 4-40 FEMALE HEX SOCKET  
 25Y = SHORT BRACKET & 4-40 SCREW

MATERIAL: COLD ROLLED STEEL  
 PLATING: CLEAR ZINC

**RoHS COMPLIANT**

**DO NOT SCALE FROM DRAWING**

	THESE DRAWINGS AND SPECIFICATIONS ARE THE PROPERTY OF NorComp AND SHALL NOT BE REPRODUCED, COPIED OR USED AS THE BASIS FOR THE MANUFACTURE OF SALE OF APPARATUS WITHOUT WRITTEN PERMISSION.		DRAWN: <b>PAM JENKINS</b>	DATE: <b>11-28-05</b>
			CHECKED:	DATE:
<h1>NorComp</h1>		SCALE: 1 : 1	SHEET 3 OF 3	REV 5
		DWG NO. <b>173-EYY-21YRYY1</b>		