

DESCRIPTION: FEMALE - DIP SOLDER - HIGH PROFILE

No. OF PINS	DIMENSIONS						
	A	B	C	D	E	F	G
9	1.213	0.984	0.642	0.315	0.618	0.496	0.429
	30.80	24.99	16.30	8.00	15.70	12.60	10.90
15	1.541	1.312	0.969	0.315	0.933	0.496	0.429
	39.15	33.32	24.60	8.00	23.70	12.60	10.90
25	2.088	1.852	1.512	0.315	1.496	0.496	0.429
	53.04	47.04	38.40	8.00	38.00	12.60	10.90
37	2.729	2.500	2.157	0.315	2.142	0.496	0.429
	69.32	63.50	54.80	8.00	54.40	12.60	10.90
50	2.635	2.406	2.059	0.425	2.039	0.602	0.535
	66.93	61.11	52.30	10.80	51.80	15.30	13.60

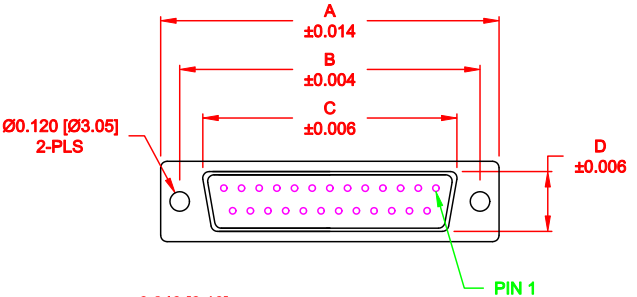

3 ROWS

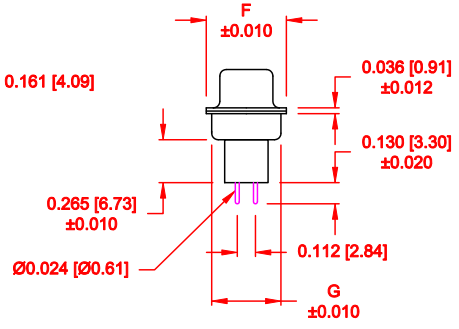
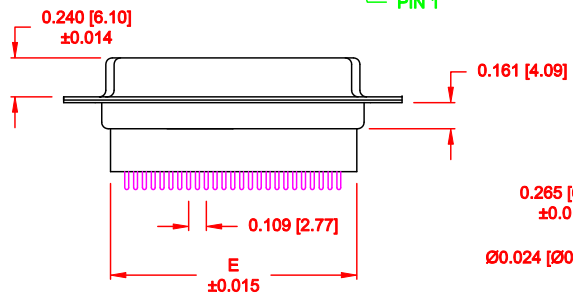

172-YYY-281LYY1

- SERIES \_\_\_\_\_
- POSITIONS \_\_\_\_\_
- 009
  - 015
  - 025
  - 037
  - 050
- GENDER \_\_\_\_\_
- 2 = FEMALE
- TERMINATION \_\_\_\_\_
- 8 = HIGH PROFILE VERTICAL
- SHELL PLATING \_\_\_\_\_
- 1 = YELLOW CHROMATE (NON-ROHS)
- HARDWARE OPTIONS \_\_\_\_\_
- 00 = NO HARDWARE
  - 01 = .098" CLINCH NUT (BOARD SIDE)
  - 02 = .236" CLINCH NUT (BOARD SIDE)
  - 03 = .236" CLINCH NUT (MATING SIDE)
- PLATING OPTIONS \_\_\_\_\_
- 1 = GOLD FLASH
  - 2 = 30u" GOLD

**MATERIAL:**  
 SHELL: STEEL, YELLOW CHROMATE  
 INSULATOR: UL 94V-O RATED, PBT-BLACK  
 PROCESS TEMP.: 230°C  
 CONTACTS: BRASS - GOLD PLATED

**ELECTRICAL:**  
 CURRENT RATING: 5 AMPS  
 CONTACT RESISTANCE: 15 mOhms Max.  
 INSULATION RESISTANCE: 1,000 MOhms min.  
 VOLTAGE: 500VAC FOR 1 MINUTE  
 TEMPERATURE: -50° C TO 125° C

DO NOT SCALE FROM DRAWING

	THESE DRAWINGS AND SPECIFICATIONS ARE THE PROPERTY OF NorComp AND SHALL NOT BE REPRODUCED, COPIED OR USED AS THE BASIS FOR THE MANUFACTURE OF SALE OF APPARATUS WITHOUT WRITTEN PERMISSION.		DRAWN: <b>WAYNE ROBBINS</b>	DATE: <b>08-23-98</b>
			CHECKED:	DATE:
NorComp		SCALE: <b>1:1</b>	SHEET <b>1</b> OF <b>3</b>	REV <b>1</b>
		DWG NO. <b>172-YYY-281LYY1</b>		

DESCRIPTION: PCB LAYOUT - STANDARD "D" - MALE & FEMALE

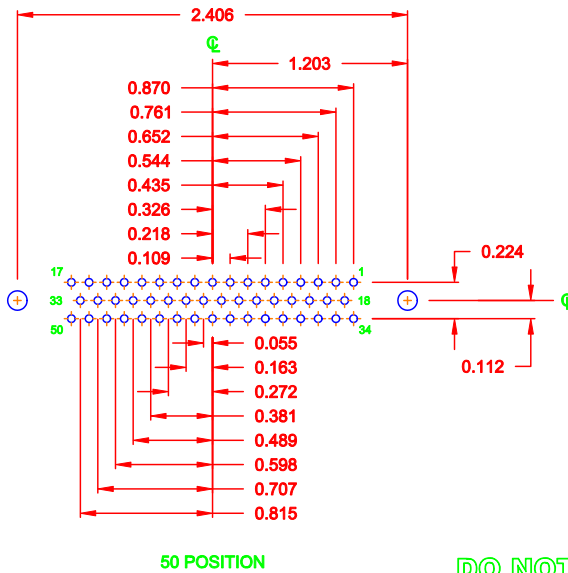
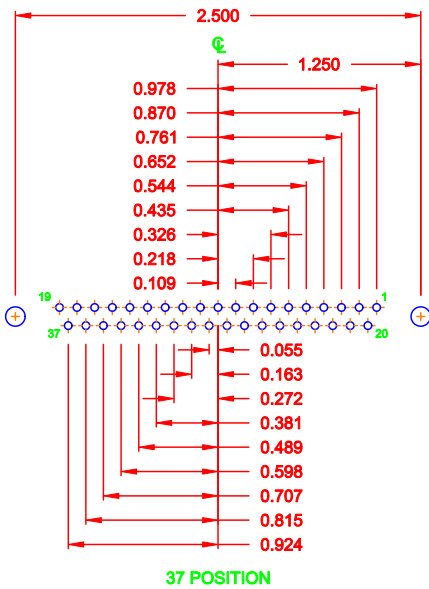
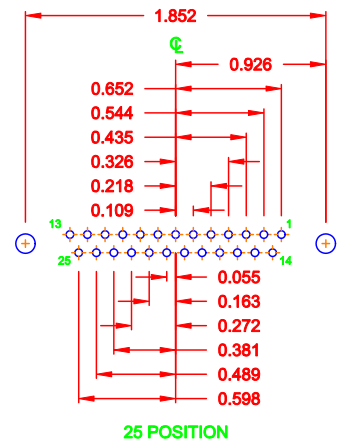
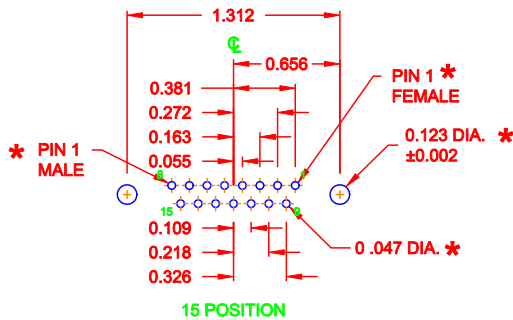
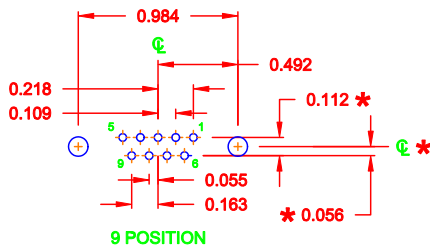

\* TYP. ON ALL SIZES

DO NOT SCALE FROM DRAWING

	THESE DRAWINGS AND SPECIFICATIONS ARE THE PROPERTY OF NorComp AND SHALL NOT BE REPRODUCED, COPIED OR USED AS THE BASIS FOR THE MANUFACTURE OF SALE OF APPARATUS WITHOUT WRITTEN PERMISSION.		DRAWN: <b>C. SMITH</b>	DATE: <b>03-08-06</b>	
	<h1>NorComp</h1>			CHECKED:	DATE:
SCALE: <b>FULL</b>				SHEET <b>2</b> OF <b>3</b>	REV <b>1</b>
DWG NO. <b>172-YYY-281LYY1</b>					

DESCRIPTION: CLINCH NUT HARDWARE

**TOLERANCE:**  
ALL DIMENSIONS ARE  $\pm 0.010$

**ALL CLINCH-NUTS ARE 4-40 INTERNAL THREADS**

01X ..... 0.065" (BOARD SIDE) - CN1

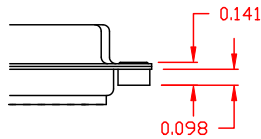

02X ..... 0.236" (BOARD SIDE) - CN2

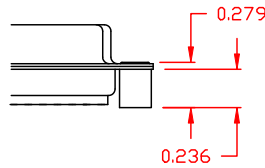

03X ..... 0.236" (MATING SIDE) - CN8

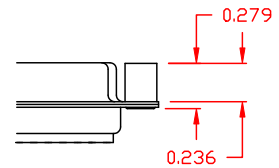

**DO NOT SCALE FROM DRAWING**

	THESE DRAWINGS AND SPECIFICATIONS ARE THE PROPERTY OF NorComp AND SHALL NOT BE REPRODUCED, COPIED OR USED AS THE BASIS FOR THE MANUFACTURE OF SALE OF APPARATUS WITHOUT WRITTEN PERMISSION.	DRAWN: <b>WAYNE ROBBINS</b>	DATE: <b>11-28-05</b>	
		CHECKED:	DATE:	
<b>NorComp</b>	SCALE:	SHEET <b>3</b>	OF <b>3</b>	REV <b>1</b>
	DWG NO.	<b>172-YYY-281LYY1</b>		