

DESCRIPTION: MALE - 0.283 RIGHT ANGLE / MACHINED - ECONOMY

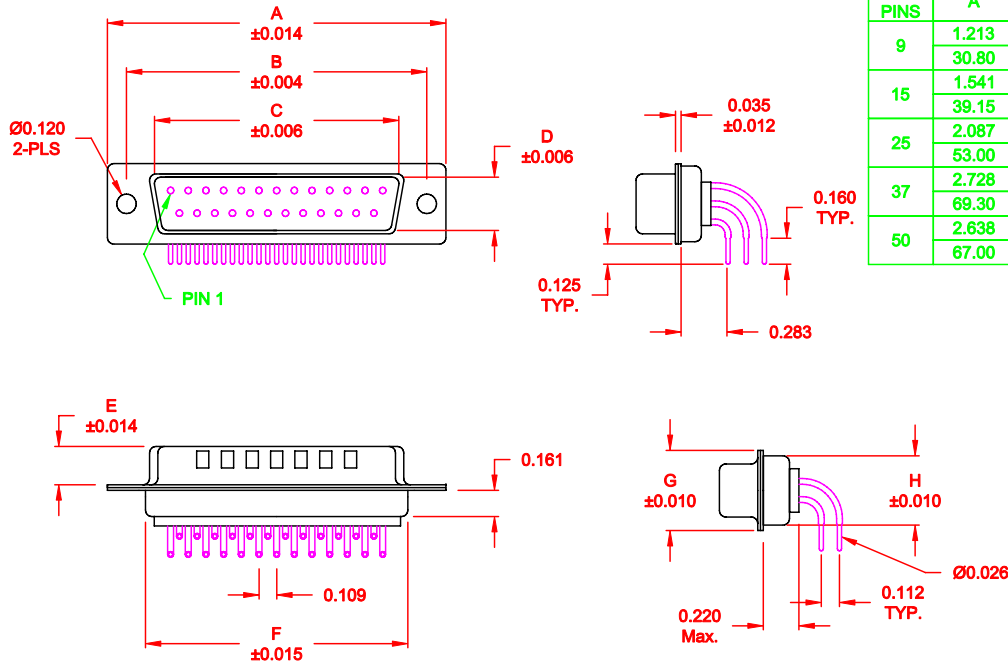

No. OF PINS	DIMENSIONS							
	A	B	C	D	E	F	G	H
9	1.213	0.984	0.666	0.329	0.236	0.756	0.496	0.427
	30.80	24.99	16.92	8.36	5.99	19.20	12.60	10.85
15	1.541	1.312	0.994	0.329	0.236	1.091	0.496	0.427
	39.15	33.32	25.25	8.36	5.99	27.70	12.60	10.85
25	2.087	1.852	1.534	0.329	0.236	1.618	0.496	0.427
	53.00	47.04	38.96	8.36	5.99	41.10	12.60	10.85
37	2.728	2.500	2.182	0.329	0.236	2.256	0.496	0.427
	69.30	63.50	55.42	8.36	5.99	57.30	12.60	10.85
50	2.638	2.406	2.079	0.436	0.240	2.169	0.602	0.527
	67.00	61.11	52.80	11.07	6.10	55.10	15.30	13.39

173-EYY-11YRY1

- SERIES
- POSITIONS
- E09
- E15
- E25
- E37
- E50
- GENDER
- 1 = MALE
- TERMINATION
- 1 = PC MOUNTING
- SHELL PLATING
- 3 = NICKEL (GROUND INDENTS)
- RoHS COMPLIANT
- HARDWARE OPTIONS
- 00 = NO HARDWARE
- 14 = SHORT BRACKET WITH 4-40 SCREW LOCK
- 24 = SHORT BRACKET WITH 4-40 SCREW
- PLATING OPTIONS
- 1 = GOLD FLASH
- 2 = 30MICRO-INCH GOLD

MATERIAL:

- SHELL: STEEL, NICKEL PLATED
- INSULATOR: UL 94V-O RATED, WHITE PA6T
- PROCESS TEMP.: 260° PROCESS TEMPERATURE
- CONTACT: BRASS

ELECTRICAL:

- CURRENT RATING: 5 AMPS
- CONTACT RESISTANCE: 15 mOhms Max.
- INSULATION RESISTANCE: 1,000 MOhms min.
- VOLTAGE: 500VAC FOR 1 MINUTE
- TEMPERATURE: -50° C TO 100° C

RoHS COMPLIANT

DO NOT SCALE FROM DRAWING

	THESE DRAWINGS AND SPECIFICATIONS ARE THE PROPERTY OF NorComp AND SHALL NOT BE REPRODUCED, COPIED OR USED AS THE BASIS FOR THE MANUFACTURE OF SALE OF APPARATUS WITHOUT WRITTEN PERMISSION.		DRAWN: WAYNE ROBBINS	DATE: 09-01-98
			CHECKED:	DATE:
<h1>NorComp</h1>		SCALE: 1:1	SHEET 1 OF 3	REV 5
		DWG NO. 173-EYY-11YRY1		

DESCRIPTION: PCB LAYOUT - MALE & FEMALE

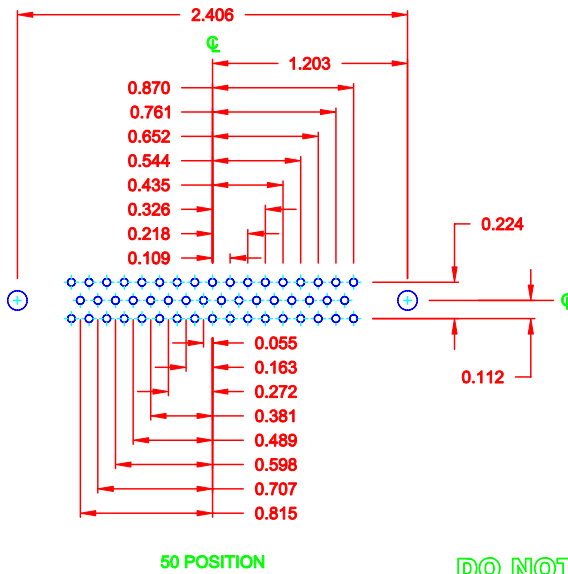
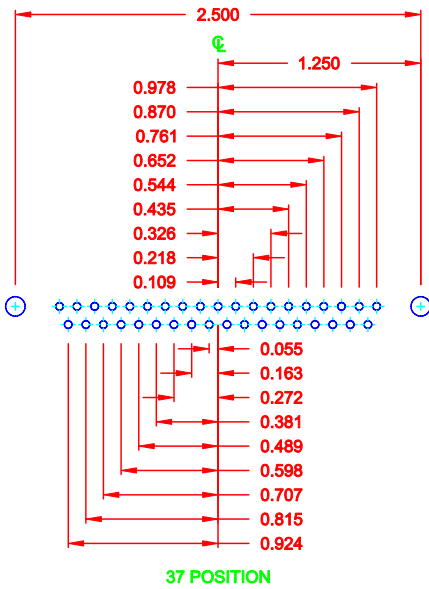
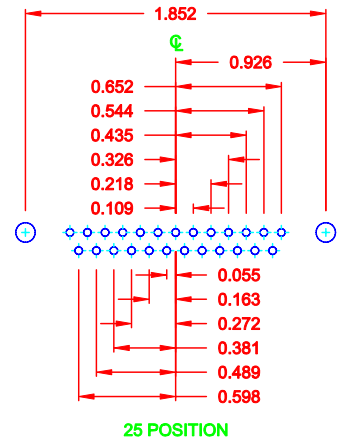
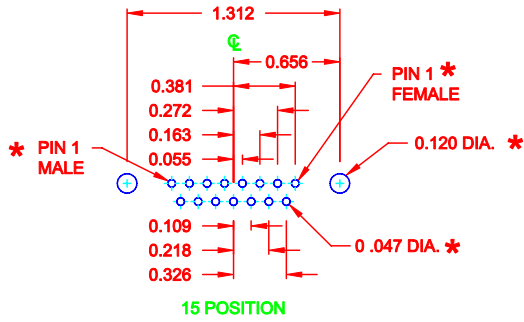
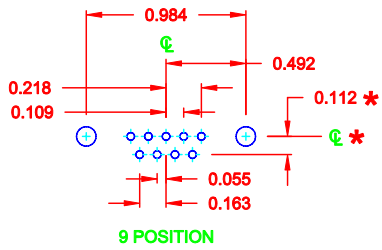

* TYP. ON ALL SIZES
UNLESS NOTED OTHERWISE

DO NOT SCALE FROM DRAWING

	THESE DRAWINGS AND SPECIFICATIONS ARE THE PROPERTY OF NorComp AND SHALL NOT BE REPRODUCED, COPIED OR USED AS THE BASIS FOR THE MANUFACTURE OF SALE OF APPARATUS WITHOUT WRITTEN PERMISSION.		DRAWN: C. SMITH	DATE: 03-08-06
	NorComp			CHECKED:
SCALE: FULL				SHEET 2 OF 3
DWG NO. 173-EYY-11YRY1				

DESCRIPTION: CLINCH NUT HARDWARE

HARDWARE OPTIONS

REPLACE -YY IN LAST 3 DIGITS WITH OPTION CHOSEN

173/174 SERIES

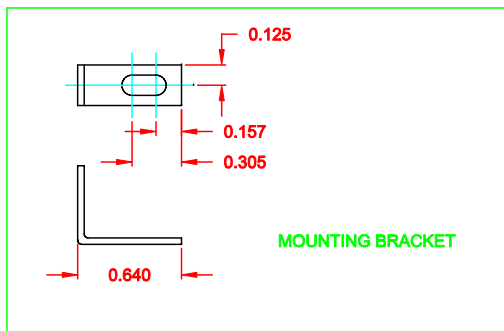

173 / 174 SERIES

14Y = SHORT BRACKET & 4-40 FEMALE HEX SOCKET
24Y = SHORT BRACKET & 4-40 SCREW

175/176 SERIES

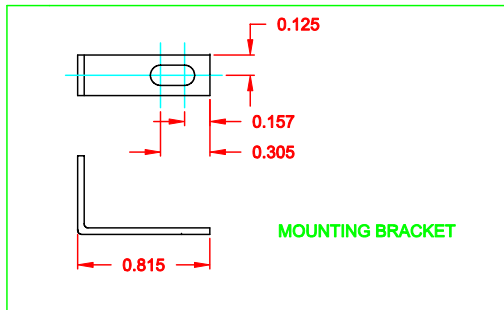

176 / 176 SERIES

15Y = LONG BRACKET & 4-40 FEMALE HEX SOCKET
25Y = SHORT BRACKET & 4-40 SCREW

MATERIAL: COLD ROLLED STEEL

PLATING: CLEAR ZINC

RoHS COMPLIANT

DO NOT SCALE FROM DRAWING

	THESE DRAWINGS AND SPECIFICATIONS ARE THE PROPERTY OF NorComp AND SHALL NOT BE REPRODUCED, COPIED OR USED AS THE BASIS FOR THE MANUFACTURE OF SALE OF APPARATUS WITHOUT WRITTEN PERMISSION.		DRAWN: PAM JENKINS	DATE: 11-28-05
			CHECKED:	DATE:
<h1>NorComp</h1>	SCALE:	SHEET 3	OF 3	REV 5
	DWG NO. 173-EYY-11YRYY1			