

DESCRIPTION: FEMALE - 0.283 RIGHT ANGLE / MACHINED - ECONOMY

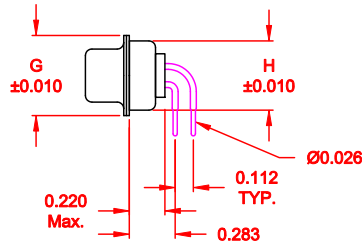
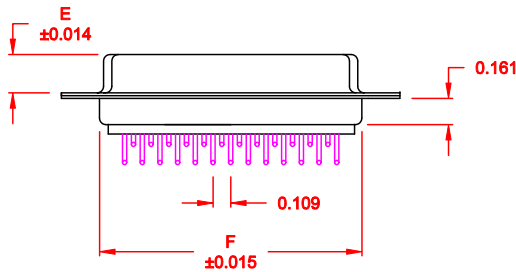
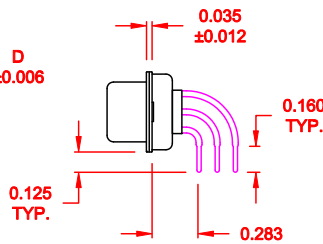
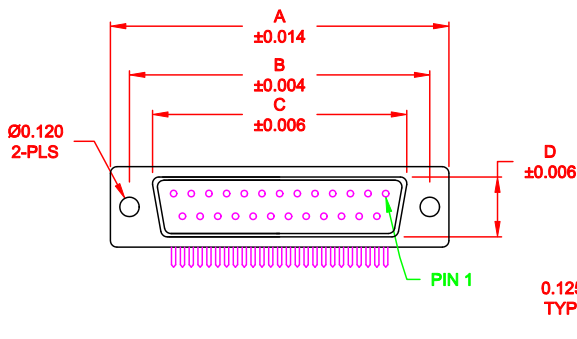

No. OF PINS	DIMENSIONS							
	A	B	C	D	E	F	G	H
9	1.213	0.984	0.642	0.311	0.236	0.756	0.496	0.427
	30.80	24.99	16.30	7.90	5.99	19.20	12.60	10.85
15	1.541	1.312	0.970	0.311	0.236	1.091	0.496	0.427
	39.15	33.32	24.65	7.90	5.99	27.70	12.60	10.85
25	2.087	1.852	1.512	0.311	0.236	1.618	0.496	0.427
	53.00	47.04	38.40	7.90	5.99	41.10	12.60	10.85
37	2.728	2.500	2.157	0.311	0.236	2.256	0.496	0.427
	69.30	63.50	54.80	7.90	5.99	57.30	12.60	10.85
50	2.638	2.406	2.055	0.429	0.240	2.169	0.602	0.527
	67.00	61.11	52.20	10.90	6.10	55.10	15.30	13.39

173-EYY-211RYY1

- SERIES _____
- POSITIONS _____
- E09 _____
- E15 _____
- E25 _____
- E37 _____
- E50 _____
- GENDER _____
- 2 = FEMALE _____
- TERMINATION _____
- 1 = PC MOUNTING _____
- SHELL PLATING _____
- 1 = YELLOW CHROMATE (NON-ROHS) _____
- HARDWARE OPTIONS _____
- 00 = NO HARDWARE _____
- 14 = SHORT BRACKET WITH 4-40 SCREW LOCK _____
- 24 = SHORT BRACKET WITH 4-40 SCREW _____
- PLATING OPTIONS _____
- 1 = GOLD FLASH _____
- 2 = 30MICRO-INCH GOLD _____

MATERIAL:

- SHELL: STEEL, YELLOW CHROMATE
 INSULATOR: UL 94V-O RATED, WHITE PA6T
 PROCESS TEMP.: 260° PROCESS TEMPERATURE
 CONTACT: BRASS

ELECTRICAL:

- CURRENT RATING: 5 AMPS
 CONTACT RESISTANCE: 15 mOhms Max.
 INSULATION RESISTANCE: 1,000 MOhms min.
 VOLTAGE: 500VAC FOR 1 MINUTE
 TEMPERATURE: -50° C TO 100° C

DO NOT SCALE FROM DRAWING

	THESE DRAWINGS AND SPECIFICATIONS ARE THE PROPERTY OF NorComp AND SHALL NOT BE REPRODUCED, COPIED OR USED AS THE BASIS FOR THE MANUFACTURE OF SALE OF APPARATUS WITHOUT WRITTEN PERMISSION.		DRAWN: WAYNE ROBBINS	DATE: 11-28-05
			CHECKED:	DATE:
NorComp		SCALE: 1:1	SHEET 1 OF 3	REV 1
		DWG NO. 173-EYY-211RYY1		

DESCRIPTION: PCB LAYOUT - MALE & FEMALE

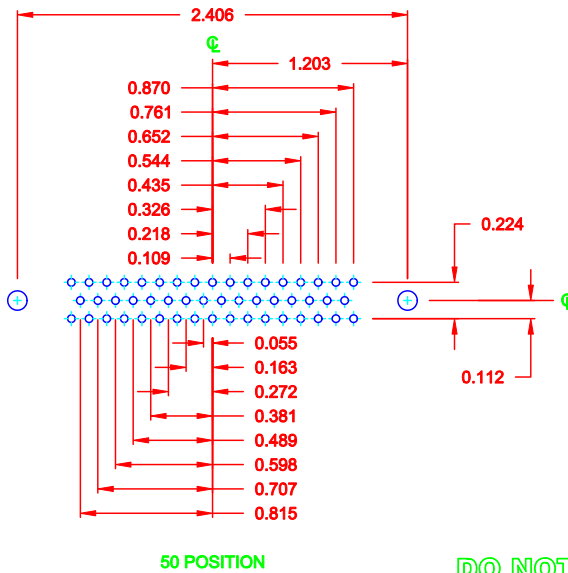
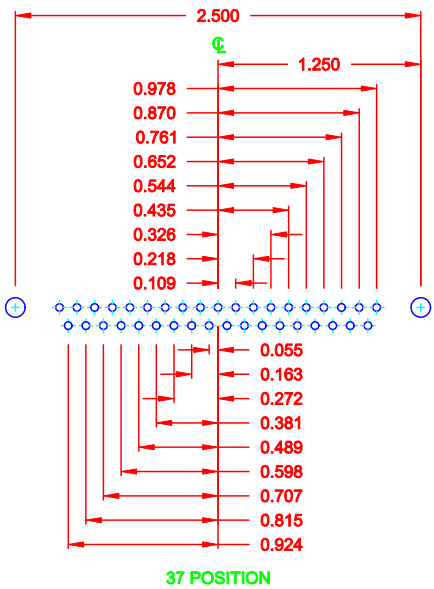
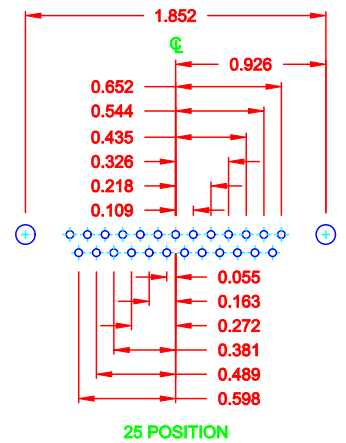
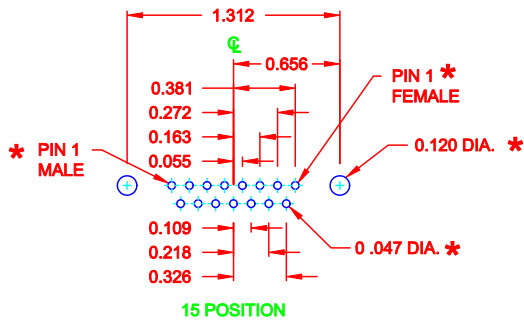
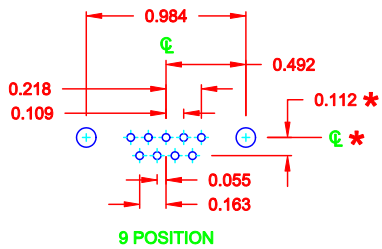

* TYP. ON ALL SIZES UNLESS NOTED OTHERWISE

DO NOT SCALE FROM DRAWING

	THESE DRAWINGS AND SPECIFICATIONS ARE THE PROPERTY OF NorComp AND SHALL NOT BE REPRODUCED, COPIED OR USED AS THE BASIS FOR THE MANUFACTURE OF SALE OF APPARATUS WITHOUT WRITTEN PERMISSION.		DRAWN: C. SMITH	DATE: 03-08-06
			CHECKED:	DATE:
<h1>NorComp</h1>	SCALE: FULL	SHEET 2	OF 3	REV 1
	DWG NO. 173-EYY-211RYY1			

DESCRIPTION: CLINCH NUT HARDWARE

HARDWARE OPTIONS

REPLACE -YY IN LAST 3 DIGITS WITH OPTION CHOSEN

173/174 SERIES

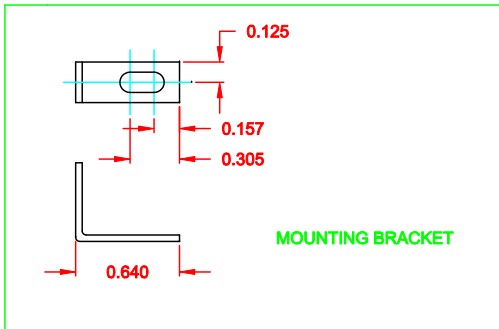

173 / 174 SERIES

14Y = SHORT BRACKET & 4-40 FEMALE HEX SOCKET
 24Y = SHORT BRACKET & 4-40 SCREW

175/176 SERIES

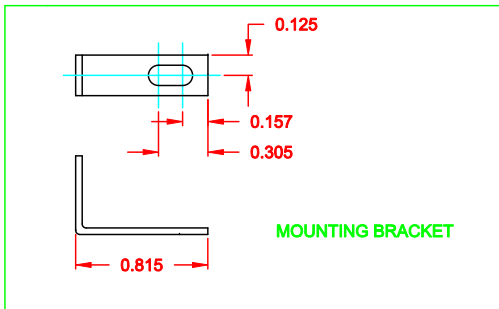

175 / 176 SERIES

15Y = LONG BRACKET & 4-40 FEMALE HEX SOCKET
 25Y = SHORT BRACKET & 4-40 SCREW

MATERIAL: COLD ROLLED STEEL

PLATING: CLEAR ZINC

DO NOT SCALE FROM DRAWING

	THESE DRAWINGS AND SPECIFICATIONS ARE THE PROPERTY OF NorComp AND SHALL NOT BE REPRODUCED, COPIED OR USED AS THE BASIS FOR THE MANUFACTURE OF SALE OF APPARATUS WITHOUT WRITTEN PERMISSION.		DRAWN: PAM JENKINS	DATE: 11-28-05
			CHECKED:	DATE:
NorComp	SCALE: 1 : 1	SHEET 3 OF 3	REV 1	
	DWG NO. 173-EYY-211RYY1			