

DESCRIPTION: DIP SOLDER FEMALE/STAMPED

**SPECIFICATIONS:**

**MATERIALS:**  
 SHELL: STEEL, NICKEL PLATED  
 INSULATOR: UL 94V-0 RATED BLACK NYLON 9T  
 CONTACTS: BRASS, GOLD PLATED  
 RoHS COMPLIANT

**ELECTRICALS:**  
 CURRENT RATING: 5 AMPS  
 CONTACT RESISTANCE: 15 mOHMS MAX  
 INSULATOR RESISTANCE: 1000 MOHMS MIN  
 VOLTAGE: 500V AC FOR 1 MINUTE  
 TEMPERATURE: -50°C TO +100°C

| POS. | A     | B     | C     | D     | E     | F     | G     |
|------|-------|-------|-------|-------|-------|-------|-------|
| 09   | 1.213 | 0.984 | 0.642 | 0.756 | 0.311 | 0.109 | 0.496 |
|      | 30.80 | 24.99 | 16.30 | 19.20 | 7.90  | 2.77  | 12.60 |
| 15   | 1.541 | 1.312 | 0.971 | 1.091 | 0.311 | 0.109 | 0.496 |
|      | 39.14 | 33.32 | 24.65 | 27.70 | 7.90  | 2.77  | 12.60 |
| 25   | 2.087 | 1.852 | 1.512 | 1.618 | 0.311 | 0.109 | 0.496 |
|      | 53.00 | 47.04 | 38.40 | 41.10 | 7.90  | 2.77  | 12.60 |
| 37   | 2.728 | 2.500 | 2.157 | 2.256 | 0.311 | 0.109 | 0.496 |
|      | 69.29 | 63.50 | 54.80 | 57.30 | 7.90  | 2.77  | 12.60 |
| 50   | 2.638 | 2.406 | 2.055 | 2.169 | 0.429 | 0.109 | 0.602 |
|      | 67.00 | 61.00 | 52.20 | 55.10 | 10.90 | 2.77  | 15.30 |

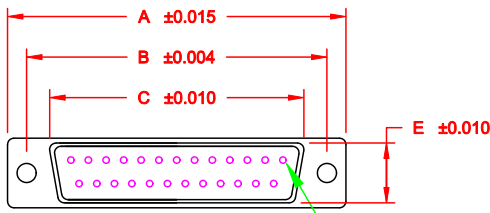

PIN #1

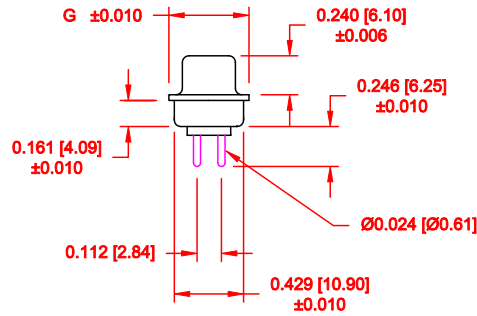
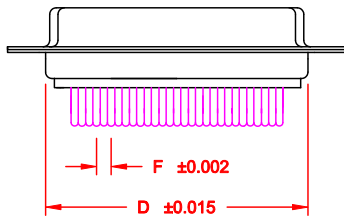

171-YYY-213RYY1

SERIES \_\_\_\_\_  
 POSITIONS \_\_\_\_\_  
 009 \_\_\_\_\_  
 015 \_\_\_\_\_  
 025 \_\_\_\_\_  
 037 \_\_\_\_\_  
 050 \_\_\_\_\_  
 GENDER \_\_\_\_\_  
 1 = MALE  
 2 = FEMALE  
 TERMINATION \_\_\_\_\_  
 1 = DIP SOLDER  
 SHELL PLATING \_\_\_\_\_  
 3 = NICKEL  
 HARDWARE OPTIONS \_\_\_\_\_  
 00 = NO HARDWARE  
 01 = .098 4-40 CLINCH NUT BOARD SIDE  
 02 = .236 4-40 CLINCH NUT BOARD SIDE  
 03 = .236 4-40 CLINCH NUT MATING SIDE  
 05 = .237 4-40 BOARD LOCK  
 91 = .237 4-40 SPACER/BOARD LOCK  
 PLATING OPTIONS \_\_\_\_\_  
 1 = GOLD FLASH  
 2 = 30 MICRO-INCH GOLD

DO NOT SCALE FROM DRAWING

RoHS COMPLIANT

|   |   |                         |                              |                         |
|---|---|-------------------------|------------------------------|-------------------------|
|  | THESE DRAWINGS AND SPECIFICATIONS ARE THE PROPERTY OF NorComp AND SHALL NOT BE REPRODUCED, COPIED OR USED AS THE BASIS FOR THE MANUFACTURE OF SALE OF APPARATUS WITHOUT WRITTEN PERMISSION. |                         | DRAWN:<br><b>PAM JENKINS</b> | DATE:<br><b>8-12-98</b> |
|   |   |                         | CHECKED:                     | DATE:                   |
| <b>NorComp</b>  |   | SCALE:                  | SHEET 1 OF 3                 | REV 6                   |
|   |   | DWG NO. 171-YYY-213RYY1 |                              |                         |

DESCRIPTION: PCB LAYOUT - STANDARD "D" - MALE & FEMALE

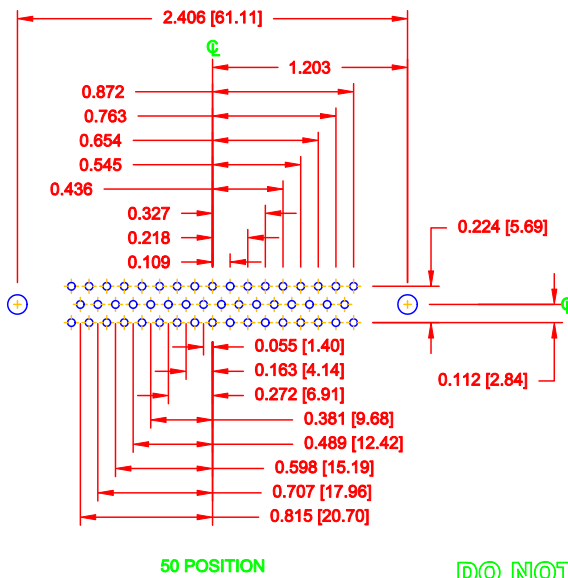
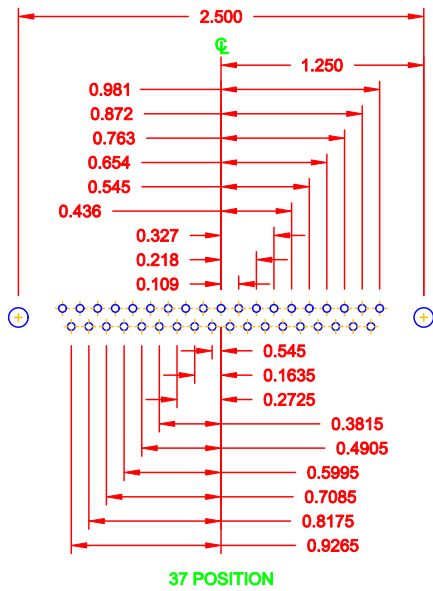
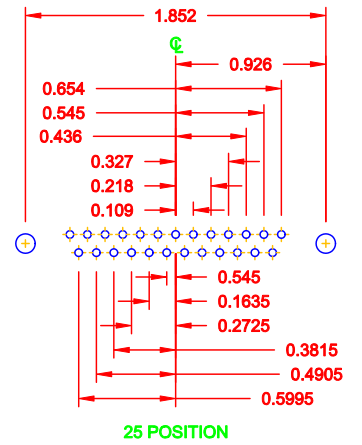
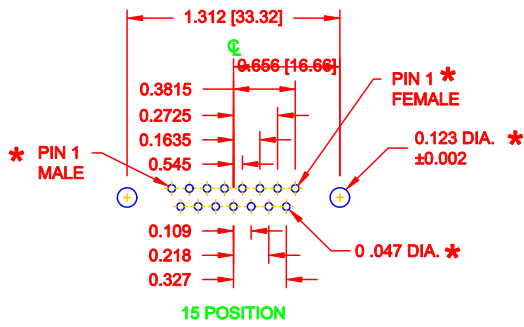
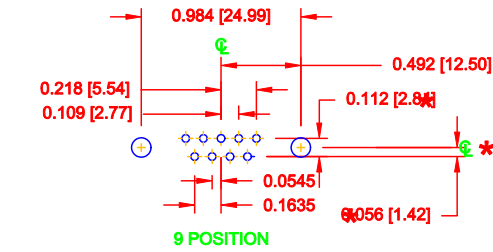

\* TYP. ON ALL SIZES

DO NOT SCALE FROM DRAWING

|   |   |                            |                        |                       |
|---|---|----------------------------|------------------------|-----------------------|
|  | THESE DRAWINGS AND SPECIFICATIONS ARE THE PROPERTY OF NorComp AND SHALL NOT BE REPRODUCED, COPIED OR USED AS THE BASIS FOR THE MANUFACTURE OF SALE OF APPARATUS WITHOUT WRITTEN PERMISSION. |                            | DRAWN: <b>C. SMITH</b> | DATE: <b>03-08-06</b> |
|   |   |                            | CHECKED:               | DATE:                 |
| <b>NorComp</b>  | SCALE: <b>FULL</b>  | SHEET <b>2</b> OF <b>3</b> | REV <b>6</b>           |                       |
|   | DWG. NO. <b>171-YYY-213YYY1</b>   |                            |                        |                       |

DESCRIPTION: CLINCH NUT HARDWARE

**TOLERANCE:**  
ALL DIMENSIONS ARE  $\pm 0.010$

**ALL CLINCH-NUTS ARE 4-40 INTERNAL THREADS**

01X ..... 0.098" (BOARD SIDE) - CN1

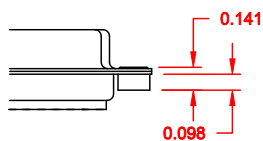

02X ..... 0.236" (BOARD SIDE) - CN2

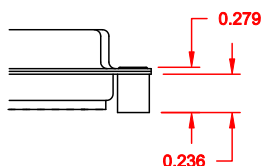

03X ..... 0.236" (MATING SIDE) - CN8

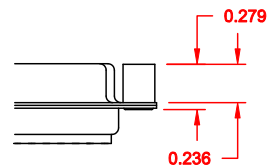

05X ..... 0.237" (BOARD SIDE) - CN10

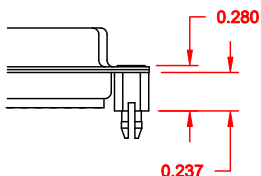

91X ..... 0.237" BOARD SIDE  
0.197 MATING SIDE  
CN10/SFSO4404

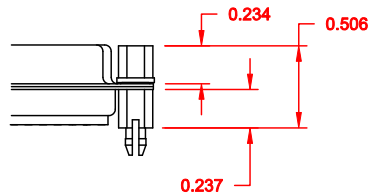

NOTE: 4-40 FEMALE SCREW LOCK IS REMOVABLE

**DO NOT SCALE FROM DRAWING**

**RoHS COMPLIANT**

|   |   |  |                                |                            |
|---|---|--|--------------------------------|----------------------------|
|  | THESE DRAWINGS AND SPECIFICATIONS ARE THE PROPERTY OF NorComp AND SHALL NOT BE REPRODUCED, COPIED OR USED AS THE BASIS FOR THE MANUFACTURE OF SALE OF APPARATUS WITHOUT WRITTEN PERMISSION. |  | DRAWN:<br><b>WAYNE ROBBINS</b> | DATE:<br><b>11-28-05</b>   |
|   | <h1>NorComp</h1>  |  |                                | CHECKED:                   |
| SCALE:  |   |  |                                | SHEET <b>3</b> OF <b>3</b> |
| <h1>NorComp</h1>  |   |  | DWG NO. <b>171-YYY-213RYY1</b> |                            |