

THIS DRAWING IS UNAPPROVED FOR REVISION
 © 2008 BY TTI ELECTRONICS CORPORATION ALL RIGHTS RESERVED

REV	DATE	DESCRIPTION	BY	APP
00				
L		REVISED FOR ECO-08-02476		

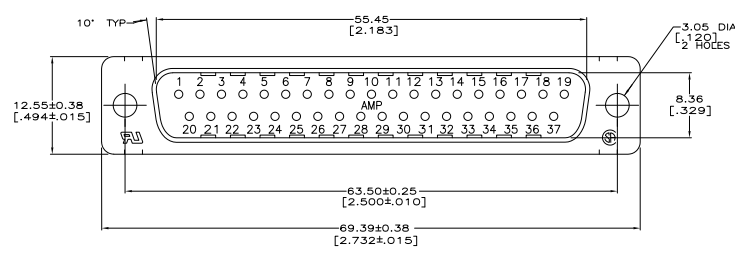

- △ HOUSING: BLACK POLYESTER, UL 94V-0 RATED
- CONTACTS: BRASS
- SHELLS: CARBON STEEL
- SCREWLOCK: ZINC
- INSERT: BRASS
- △ GOLD FLASH FOR LENGTH OF 3.81 [150] MIN FROM MATING END, 2.54μm [0.00100] MIN TIN OR TIN-LEAD FOR A LENGTH OF DIMENSION A FROM OPPOSITE END, BOTH OVER 1.27μm [0.00050] MIN NICKEL.
- △ GOLD PLATED FOR LENGTH OF 3.81 [150] MIN FROM MATING END, 0.76μm [0.00030] MIN GOLD IN MATED AREA, 2.54μm [0.00100] MIN TIN OR TIN-LEAD FOR A LENGTH OF DIMENSION A FROM OPPOSITE END, BOTH OVER 1.27μm [0.00050] MIN NICKEL.
- OR-
- △ GOLD FLASH OVER PALLADIUM NICKEL FOR A LENGTH OF 3.81 [150] MIN FROM MATING END, 0.76μm [0.00030] MIN PALLADIUM NICKEL IN MATED AREA, 2.54μm [0.00100] MIN TIN OR TIN-LEAD FOR A LENGTH OF DIMENSION A FROM OPPOSITE END, BOTH OVER 1.27μm [0.00050] MIN NICKEL.
- △ SHELLS: 5.08μm [0.00200] MIN TIN OVER 2.54μm [0.00100] MIN COPPER
- CONTACTS: SEE TABLE
- △ DATUMS AND BASIC DIMENSIONS ESTABLISHED BY CUSTOMERS.
- △ 2.79[110] MAX IN SHELL TAB CLINCH AREAS.

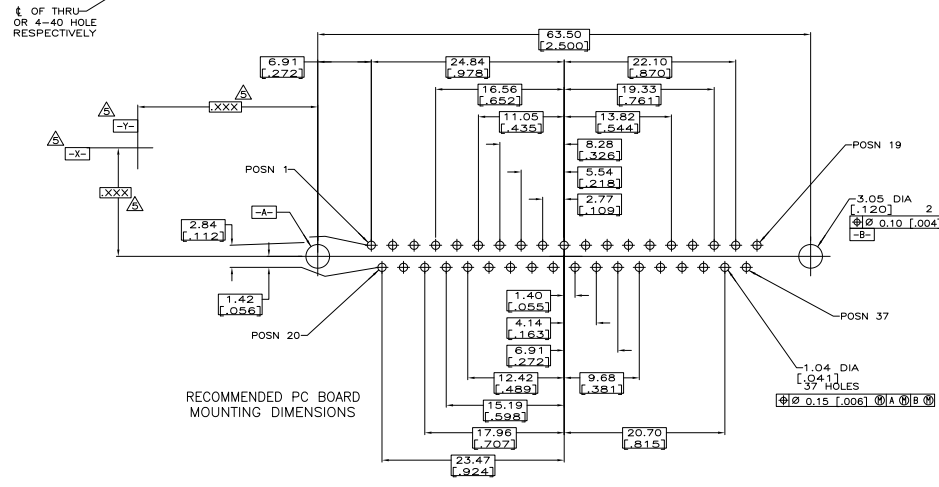
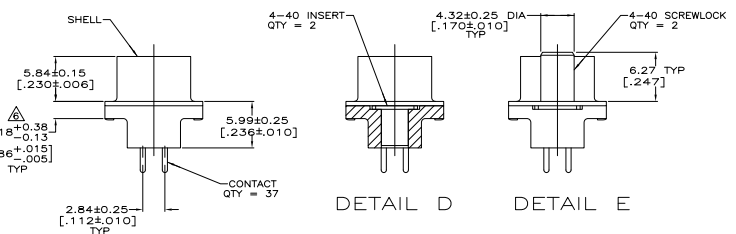
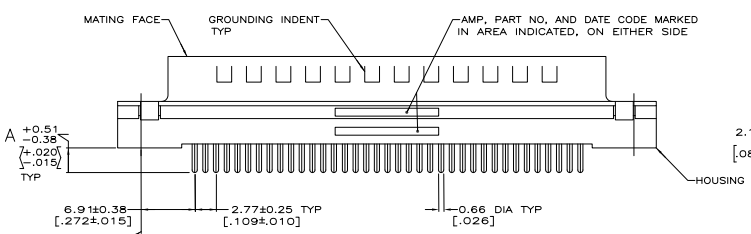

REV	DATE	DESCRIPTION	BY	APP
00				
L		REVISED FOR ECO-08-02476		

REV	DATE	DESCRIPTION	BY	APP
00				
L		REVISED FOR ECO-08-02476		

REV	DATE	DESCRIPTION	BY	APP
00				
L		REVISED FOR ECO-08-02476		

REV	DATE	DESCRIPTION	BY	APP
00				
L		REVISED FOR ECO-08-02476		

REV	DATE	DESCRIPTION	BY	APP
00				
L		REVISED FOR ECO-08-02476		

REV	DATE	DESCRIPTION	BY	APP
00				
L		REVISED FOR ECO-08-02476		

REV	DATE	DESCRIPTION	BY	APP
00				
L		REVISED FOR ECO-08-02476		

REV	DATE	DESCRIPTION	BY	APP
00				
L		REVISED FOR ECO-08-02476		

REV	DATE	DESCRIPTION	BY	APP
00				
L		REVISED FOR ECO-08-02476		

REV	DATE	DESCRIPTION	BY	APP
00				
L		REVISED FOR ECO-08-02476		

REV	DATE	DESCRIPTION	BY	APP
00				
L		REVISED FOR ECO-08-02476		

REV	DATE	DESCRIPTION	BY	APP
00				
L		REVISED FOR ECO-08-02476		

REV	DATE	DESCRIPTION	BY	APP
00				
L		REVISED FOR ECO-08-02476		

REV	DATE	DESCRIPTION	BY	APP
00				
L		REVISED FOR ECO-08-02476		

REV	DATE	DESCRIPTION	BY	APP
00				
L		REVISED FOR ECO-08-02476		

REV	DATE	DESCRIPTION	BY	APP
00				
L		REVISED FOR ECO-08-02476		

REV	DATE	DESCRIPTION	BY	APP
00				
L		REVISED FOR ECO-08-02476		

REV	DATE	DESCRIPTION	BY	APP
00				
L		REVISED FOR ECO-08-02476		

REV	DATE	DESCRIPTION	BY	APP
00				
L		REVISED FOR ECO-08-02476		

REV	DATE	DESCRIPTION	BY	APP
00				
L		REVISED FOR ECO-08-02476		

REV	DATE	DESCRIPTION	BY	APP
00				
L		REVISED FOR ECO-08-02476		

REV	DATE	DESCRIPTION	BY	APP
00				
L		REVISED FOR ECO-08-02476		

REV	DATE	DESCRIPTION	BY	APP
00				
L		REVISED FOR ECO-08-02476		

REV	DATE	DESCRIPTION	BY	APP
00				
L		REVISED FOR ECO-08-02476		

REV	DATE	DESCRIPTION	BY	APP
00				
L		REVISED FOR ECO-08-02476		

REV	DATE	DESCRIPTION	BY	APP
00				
L		REVISED FOR ECO-08-02476		

REV	DATE	DESCRIPTION	BY	APP
00				
L		REVISED FOR ECO-08-02476		

REV	DATE	DESCRIPTION	BY	APP
00				
L		REVISED FOR ECO-08-02476		

REV	DATE	DESCRIPTION	BY	APP
00				
L		REVISED FOR ECO-08-02476		

REV	DATE	DESCRIPTION	BY	APP
00				
L		REVISED FOR ECO-08-02476		

REV	DATE	DESCRIPTION	BY	APP
00				
L		REVISED FOR ECO-08-02476		

REV	DATE	DESCRIPTION	BY	APP
00				
L		REVISED FOR ECO-08-02476		

REV	DATE	DESCRIPTION	BY	APP
00				
L		REVISED FOR ECO-08-02476		

REV	DATE	DESCRIPTION	BY	APP
00				
L		REVISED FOR ECO-08-02476		

REV	DATE	DESCRIPTION	BY	APP
00				
L		REVISED FOR ECO-08-02476		

REV	DATE	DESCRIPTION	BY	APP
00				
L		REVISED FOR ECO-08-02476		

REV	DATE	DESCRIPTION	BY	APP
00				
L		REVISED FOR ECO-08-02476		

REV	DATE	DESCRIPTION	BY	APP
00				
L		REVISED FOR ECO-08-02476		

REV	DATE	DESCRIPTION	BY	APP
00				
L		REVISED FOR ECO-08-02476		

REV	DATE	DESCRIPTION	BY	APP
00				
L		REVISED FOR ECO-08-02476		

REV	DATE	DESCRIPTION	BY	APP
00				
L		REVISED FOR ECO-08-02476		

REV	DATE	DESCRIPTION	BY	APP
00				
L		REVISED FOR ECO-08-02476		

REV	DATE	DESCRIPTION	BY	APP
00				
L		REVISED FOR ECO-08-02476		

REV	DATE	DESCRIPTION	BY	APP
00				
L		REVISED FOR ECO-08-02476		

REV	DATE	DESCRIPTION	BY	APP
00				
L		REVISED FOR ECO-08-02476		

REV	DATE	DESCRIPTION	BY	APP
00				
L		REVISED FOR ECO-08-02476		

REV	DATE	DESCRIPTION	BY	APP
00				
L		REVISED FOR ECO-08-02476		

REV	DATE	DESCRIPTION	BY	APP
00				
L		REVISED FOR ECO-08-02476		

REV	DATE	DESCRIPTION	BY	APP
00				
L		REVISED FOR ECO-08-02476		

REV	DATE	DESCRIPTION	BY	APP
00				
L		REVISED FOR ECO-08-02476		

REV	DATE	DESCRIPTION	BY	APP
00				
L		REVISED FOR ECO-08-02476		

REV	DATE	DESCRIPTION	BY	APP
00				
L		REVISED FOR ECO-08-02476		

REV	DATE	DESCRIPTION	BY	APP
00				
L		REVISED FOR ECO-08-02476		

REV	DATE	DESCRIPTION	BY	APP
00				
L		REVISED FOR ECO-08-02476		

REV	DATE	DESCRIPTION	BY	APP
00				
L		REVISED FOR ECO-08-02476		

REV	DATE	DESCRIPTION	BY	APP
00				
L		REVISED FOR ECO-08-02476		

REV	DATE	DESCRIPTION	BY	APP
00				
L		REVISED FOR ECO-08-02476		

REV	DATE	DESCRIPTION	BY	APP
00				
L		REVISED FOR ECO-08-02476		

REV	DATE	DESCRIPTION	BY	APP
00				
L		REVISED FOR ECO-08-02476		

REV	DATE	DESCRIPTION	BY	APP
00				
L		REVISED FOR ECO-08-02476		

REV	DATE	DESCRIPTION	BY	APP
00				
L		REVISED FOR ECO-08-02476		

REV	DATE	DESCRIPTION	BY	APP
00				
L		REVISED FOR ECO-08-02476		

REV	DATE	DESCRIPTION	BY	APP
00				
L		REVISED FOR ECO-08-02476		

REV	DATE	DESCRIPTION	BY	APP
00				
L		REVISED FOR ECO-08-02476		

REV	DATE	DESCRIPTION	BY	APP
00				
L		REVISED FOR ECO-08-02476		

REV	DATE	DESCRIPTION	BY	APP
00				
L		REVISED FOR ECO-08-02476		

REV	DATE	DESCRIPTION	BY	APP
00				
L		REVISED FOR ECO-08-02476		

REV	DATE	DESCRIPTION	BY	APP
00				
L		REVISED FOR ECO-08-02476		

REV	DATE	DESCRIPTION	BY	APP
00				
L		REVISED FOR ECO-08-02476		

REV	DATE	DESCRIPTION	BY	APP
00				
L		REVISED FOR ECO-08-02476		

REV	DATE	DESCRIPTION	BY	APP
00				
L		REVISED FOR ECO-08-02476		

REV	DATE	DESCRIPTION	BY	APP
00				
L		REVISED FOR ECO-08-02476		

REV	DATE	DESCRIPTION	BY	APP
00				
L		REVISED FOR ECO-08-02476		</