

THIS DRAWING IS UNPUBLISHED. RELEASED FOR PUBLICATION  
 © COPYRIGHT 19 BY AMP INCORPORATED. ALL INTERNATIONAL RIGHTS RESERVED.

LOC	DIST	P	F	ZONE	LTR	DESCRIPTION	DATE	APPO
BD	77							
						C REDRAWN & REVISED, ECN 803361	11-89	SS
						D OBS 745057-5, -8 8D6038	08/09/92	CR
						E OBS -6, -7 PER EC 0020-964-93	04/11/94	CR

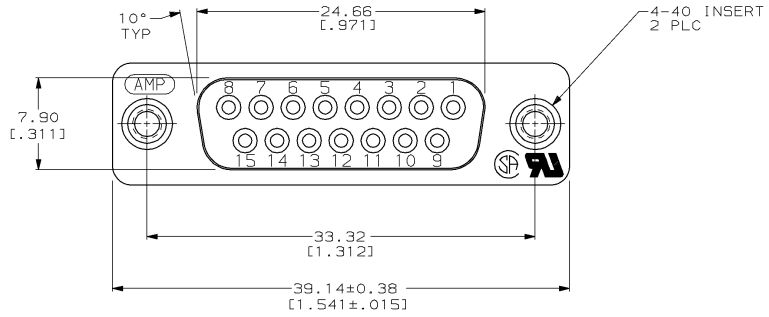

- ① HOUSING: BLACK POLYESTER, UL 94V-0 RATED; CONTACTS: PHOSPHOR BRONZE PER QQ-B-750; INSERTS: BRASS PER QQ-B-626.
- ② GOLD PLATING PER MIL-G-45204, TIN PLATING PER MIL-T-10727, NICKEL PLATING PER QQ-N-290.
- ③ GOLD FLASH FOR A LENGTH OF 2.54 [1.00] MIN FROM MATING END, 2.54µm [0.000100] MIN TIN OR TIN-LEAD FOR A LENGTH OF DIMENSION A FROM OPPOSITE END, ALL OVER 1.27µm [0.000050] MIN NICKEL.
- ④ 0.76µm [0.000030] MIN GOLD FOR A LENGTH OF 2.54 [1.00] MIN FROM MATING END, 2.54µm [0.000100] MIN TIN OR TIN-LEAD FOR A LENGTH OF DIMENSION A FROM OPPOSITE END, ALL OVER 1.27µm [0.000050] MIN NICKEL.

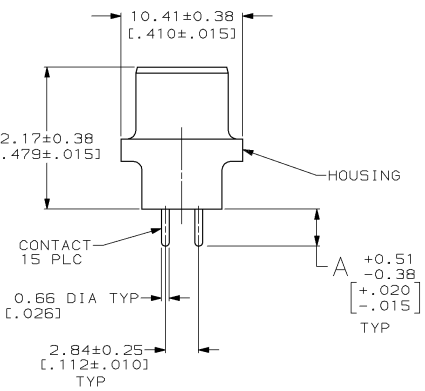
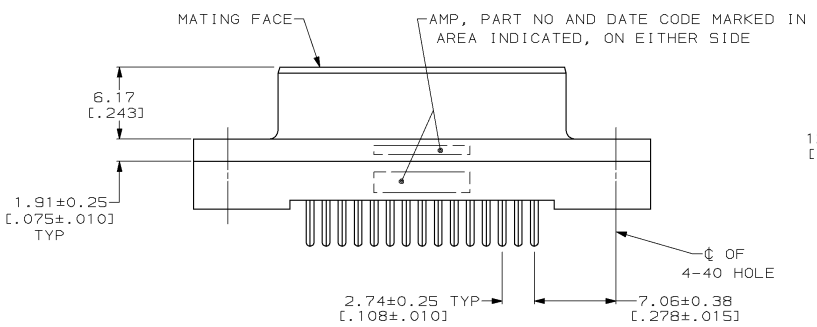

REVISED	DATE	DESCRIPTION	BY	CHKD
OBSOLETE	6.35 [0.250]	④		745057-8
OBSOLETE	6.35 [0.250]	③		745057-7
OBSOLETE	4.32 [0.170]	③ ④		745057-6
OBSOLETE	4.32 [0.170]	③		745057-5
	3.18 [0.125]	③ ④		745057-4
	3.18 [0.125]	③		745057-3

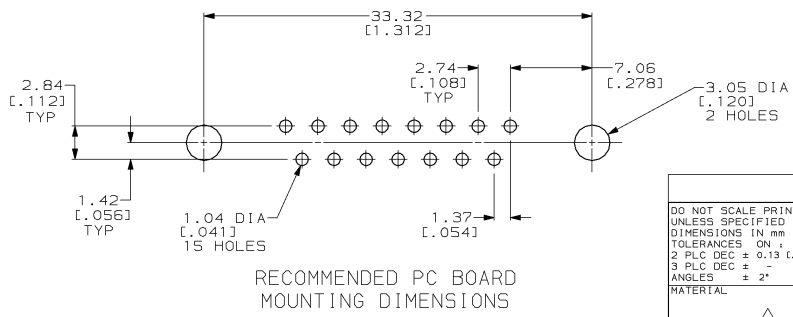

DO NOT SCALE PRINT. UNLESS SPECIFIED DIMENSIONS IN mm [INCHES]	DR 11-16-89 J McCLINTON	AMP INCORPORATED Harrisburg, Pa. 17105
TOLERANCES ON: 2 PLC DEC ± 0.13 [0.005] 3 PLC DEC ± ANGLES ± 2°	CHK 2-1-90 R. STONE	NAME <b>RECEPTACLE ASSEMBLY, SIZE 2, 15 POSN, VERTICAL, AMPLIMITE® HD-20</b>
MATERIAL	APPD 2-2-90 S. SCHIEFERLY	
FINISH ②	APPD 2-2-90 C. ROHDE	SIZE <b>C</b> CAGE CODE <b>00779</b> DRAWING NO <b>745057</b>
CONTACT: SEE TABLE	PRODUCT SPEC 108-40025	SCALE 4:1 SHEET 1 OF 1
	APPLICATION SPEC	
	WEIGHT	