

- △ HOUSING: NYLON OR POLYESTER, FLAME RETARDANT, UL 94V-0 RATED, GLASS FILLED, BLACK.
- CONTACTS: BRASS
- SHELL: CARBON STEEL
- EYELETS: BRASS
- INSERTS & SCREWLOCKS: ZINC
- △ SHELL: 2.54µm [.000100] MIN TIN OVER 1.27µm [.000050] MIN COPPER.
- EYELETS: 2.54µm [.000100] MIN TIN OVER COPPER FLASH.
- INSERTS & SCREWLOCKS: CLEAR CHROMATE
- CONTACTS: SEE TABLE
- △ GOLD PLATED FOR LENGTH OF 3.81 [.150] MIN FROM MATING END, GOLD FLASH IN MATED AREA, 2.54µm [.000100] MIN TIN FOR A LENGTH OF 3.56 [.140] MIN FROM OPPOSITE END, BOTH 1.27µm [.000050] MIN NICKEL.
- △ GOLD PLATED FOR A LENGTH OF 3.81 [.150] MIN FROM MATING END, 0.76µm [.000030] MIN GOLD IN MATED AREA, 2.54µm [.000100] MIN TIN FOR A LENGTH OF 3.56 [.140] MIN FROM OPPOSITE END, ALL OVER 1.27µm [.000050] MIN NICKEL.
- OR-
- GOLD FLASH OVER PALLADIUM NICKEL PLATED FOR A LENGTH OF 3.81 [.150] MIN FROM MATING END, 0.76µm [.000030] MIN PALLADIUM NICKEL IN MATED AREA, 2.54µm [.000100] MIN TIN FOR A LENGTH OF 3.54 [.140] MIN FROM OPPOSITE END, ALL OVER 1.27µm [.000050] MIN NICKEL.

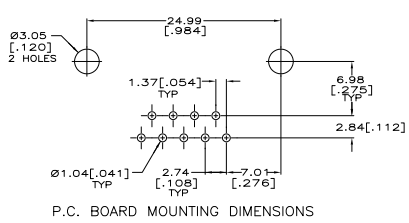
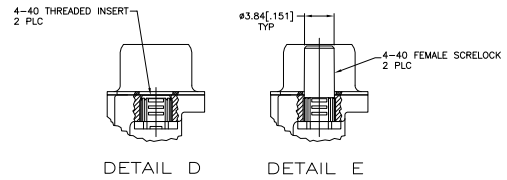
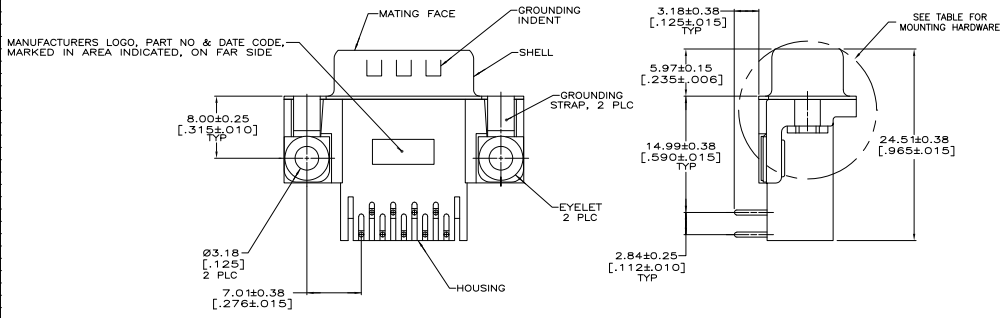

SEE DETAIL E	△	5745990-6
SEE DETAIL D	△	5745990-4
SEE DETAIL D	△	5745990-3
MOUNTING HARDWARE	CONTACT FINISH	PART NUMBER

THIS DRAWING IS A CONTROLLED DOCUMENT. DATE: 06-25-07. BY: J. FERNANDEZ. CHECKED: J. SOLASH. TTI ELECTRONICS CORPORATION, Harrisburg, PA 17105-3608.

INCHES	MM	108-40025	PLUG ASSEMBLY, SIZE 1, 9 POSITION, RIGHT ANGLE, FRONT METAL SHELL, 500 SERIES, AMPULITE, HD-20
1:1	1:1	114-40010	REWORKED TO
CUSTOMER DRAWING		DATE: 06-25-07	REV: 1