

REV	DATE	DESCRIPTION	BY	CHK	APP
GP 00					
A		REVISED PER ECO-06-03833			3/24/07 ZMR/EDB

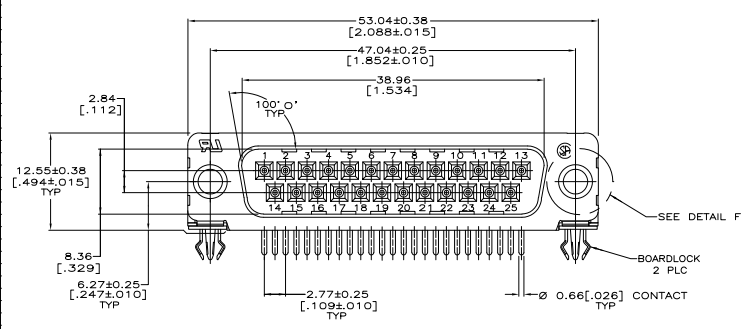

△ HOUSING: NYLON OR POLYESTER, FLAME RETARDANT, UL 94V-0 RATED, GLASS FILLED, BLACK.
 CONTACTS: BRASS
 SHELL: CARBON STEEL
 EYELETS: BRASS
 BOARDLOCKS: COPPER ALLOY
 SCREWS/LOCKS & INSERTS: ZINC

△ SHELL: 2.54µm [0.000100] MIN TIN OVER 1.27µm [0.000050] MIN COPPER.
 EYELETS: 2.54µm [0.000100] MIN TIN OVER COPPER FLASH.
 BOARDLOCKS: 3.81µm [0.000150] MIN TIN OVER 1.27µm [0.000050] MIN NICKEL.
 CONTACTS: GOLD PLATED FOR A LENGTH OF 3.81 [0.150] MIN FROM MATING END, 0.76µm [0.000030] MIN GOLD IN MATED AREA, 2.54µm [0.000100] MIN TIN FOR A LENGTH OF 3.58 [0.140] MIN FROM OPPOSITE END, BOTH OVER 1.27µm [0.000050] MIN NICKEL.
 -OR-
 GOLD FLASH OVER PALLADIUM NICKEL PLATED FOR A LENGTH OF 3.81 [0.150] MIN FROM MATING END, 0.76µm [0.000030] MIN PALLADIUM NICKEL IN MATED AREA, 2.54µm [0.000100] MIN TIN FOR A LENGTH OF 3.58 [0.140] MIN FROM OPPOSITE END, BOTH OVER 1.27µm [0.000050] MIN NICKEL.
 SCREWS/LOCKS & INSERTS: CLEAR CHROMATE

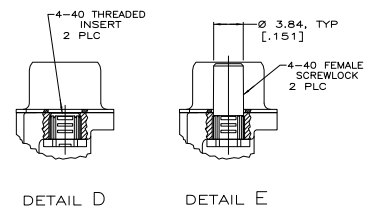
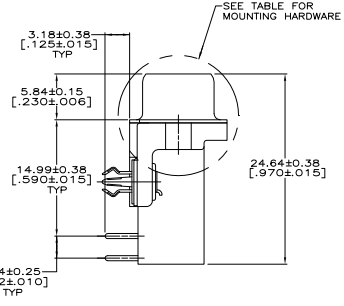
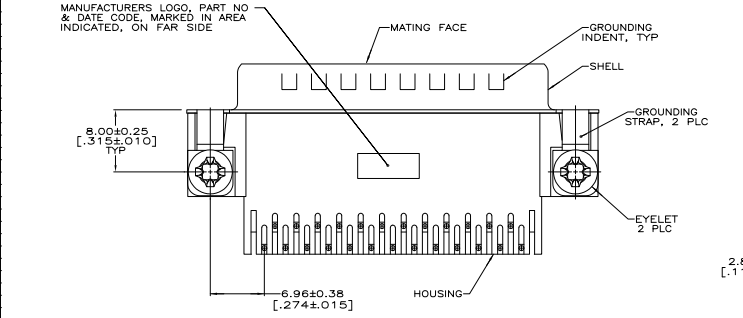

RECOMMENDED P.C. BOARD MOUNTING DIMENSIONS
 P.C. BOARD THICKNESS: 1.57[0.062]

**COPYRIGHT 2005
 TYCO ELECTRONICS CORP
 ALL RIGHTS RESERVED**

SEE DETAIL E	5747834-6
SEE DETAIL D	5747834-4
MOUNTING HARDWARE	PART NUMBER

THIS DRAWING IS A CONTROLLED DOCUMENT		REV: 00	DATE: 06-11-07	BY: [Signature]	CHK: [Signature]	APP: [Signature]	DATE: 06-11-07	BY: [Signature]	CHK: [Signature]	APP: [Signature]	DATE: 06-11-07
DESIGNED BY: M. WILMSLEY	DESIGNED DATE: 06-11-07	REVISED BY: M. WILMSLEY	REVISED DATE: 06-11-07	REVISED BY: M. WILMSLEY	REVISED DATE: 06-11-07	REVISED BY: M. WILMSLEY	REVISED DATE: 06-11-07	REVISED BY: M. WILMSLEY	REVISED DATE: 06-11-07	REVISED BY: M. WILMSLEY	REVISED DATE: 06-11-07
DESCRIPTION: PLUG ASSEMBLY, SIZE 3, 25 POSITION, RIGHT ANGLE, FRONT METAL SHELL, 590 SERIES, BOARDLOCKS, ANTIPLATE HD-20	QUANTITY: 108-40025	DATE: 06-11-07	BY: M. WILMSLEY	CHK: [Signature]	APP: [Signature]	DATE: 06-11-07	BY: M. WILMSLEY	CHK: [Signature]	APP: [Signature]	DATE: 06-11-07	BY: M. WILMSLEY
REVISED BY: M. WILMSLEY	REVISED DATE: 06-11-07	REVISED BY: M. WILMSLEY	REVISED DATE: 06-11-07	REVISED BY: M. WILMSLEY	REVISED DATE: 06-11-07	REVISED BY: M. WILMSLEY	REVISED DATE: 06-11-07	REVISED BY: M. WILMSLEY	REVISED DATE: 06-11-07	REVISED BY: M. WILMSLEY	REVISED DATE: 06-11-07
DATE: 06-11-07	BY: M. WILMSLEY	CHK: [Signature]	APP: [Signature]	DATE: 06-11-07	BY: M. WILMSLEY	CHK: [Signature]	APP: [Signature]	DATE: 06-11-07	BY: M. WILMSLEY	CHK: [Signature]	APP: [Signature]
CUSTOMER DRAWING	DATE: 06-11-07	BY: M. WILMSLEY	CHK: [Signature]	APP: [Signature]	DATE: 06-11-07	BY: M. WILMSLEY	CHK: [Signature]	APP: [Signature]	DATE: 06-11-07	BY: M. WILMSLEY	CHK: [Signature]