



4

3

2

1

THIS DRAWING IS UNPUBLISHED. RELEASED FOR PUBLICATION  
 © COPYRIGHT BY TYCO ELECTRONICS CORPORATION. ALL RIGHTS RESERVED.

LOC	DIST	REVISIONS			
P	LTR	DESCRIPTION	DATE	DWN	APVD
		SEE SHEET 1.			

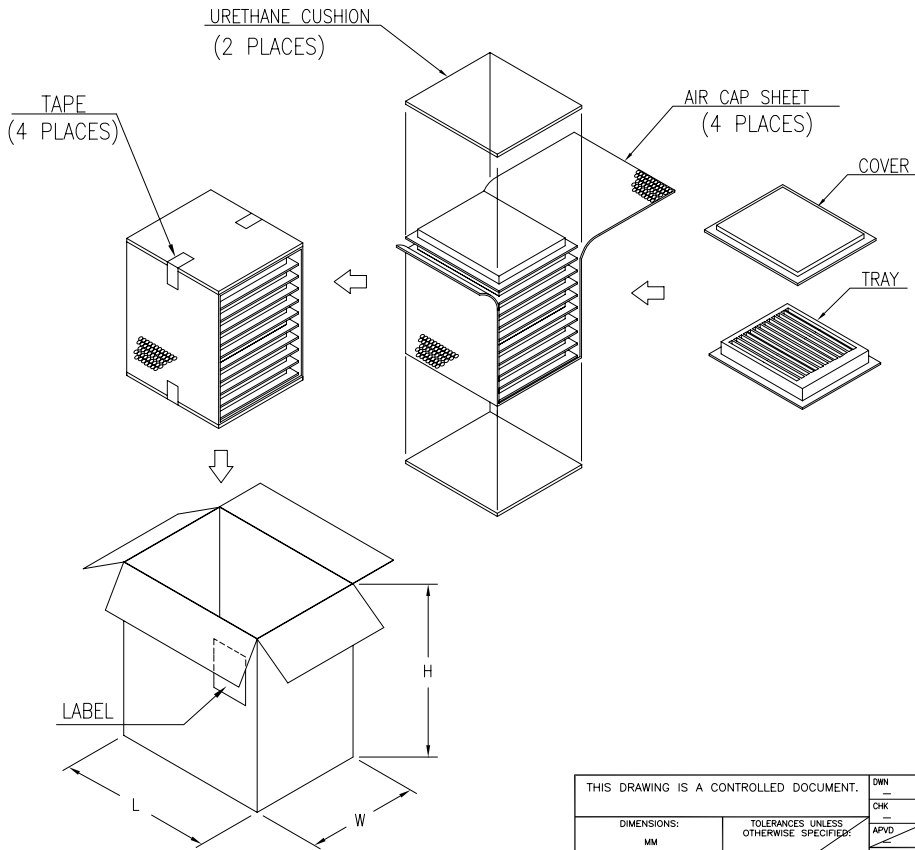

- NOTES:
- MATERIAL:
    - 1.1 TRAY: PVC
    - 1.2 SHIPPING CARTON: CORRUGATED FIBERBOARD
  - DIMENSION:
    - 2.1 TRAY: L=320, W=230, H=18.9
    - 2.2 SHIPPING CARTON: L=361, W=245, H=272
  - QUANTITY:
    - 3.1 PRIMARY PACKING: 100 PCS/TRAY
    - 3.2 SECONDARY PACKING: 10 TRAY/CARTON(1000PCS)
  - CARTON WEIGHT:
    - 4.1 NET WEIGHT: 10.24 Kg (W/SCREWLOCK)
    - 4.2 GROSS WEIGHT: 11.24 Kg (W/SCREWLOCK)
    - 4.3 NET WEIGHT: 8.24 Kg (W/O SCREWLOCK)
    - 4.4 GROSS WEIGHT: 9.24 Kg (W/O SCREWLOCK)

THIS DRAWING IS A CONTROLLED DOCUMENT.		DWN	Tyco Electronics Corporation	
		CHK	Taipei, Taiwan	
DIMENSIONS:		APVD	NAME	
MM	TOLERANCES UNLESS OTHERWISE SPECIFIED:	RECEPTACLE ASSY, SIZE 1, 15 POSITION, RIGHT ANGLE, THROUGH HOLE		
	0 PLC ±	PRODUCT SPEC		
	1 PLC ±	APPLICATION SPEC		
	2 PLC ±	SIZE	CAGE CODE	DRAWING NO
	3 PLC ±	A3	00779	C=1734530
	4 PLC ±	WEIGHT		RESTRICTED TO
	ANGLES ±	CUSTOMER DRAWING		—
MATERIAL	FINISH	SCALE	SHEET	REV
			2 of 4	B

THIS DRAWING IS UNPUBLISHED. RELEASED FOR PUBLICATION  
 © COPYRIGHT BY TYCO ELECTRONICS CORPORATION. ALL RIGHTS RESERVED.

LOC		DIST		REVISIONS			
P	LTR	DESCRIPTION	DATE	DWN	APVD		
		SEE SHEET 1.					

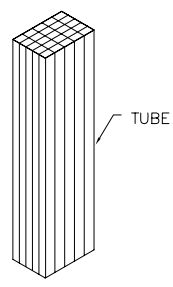
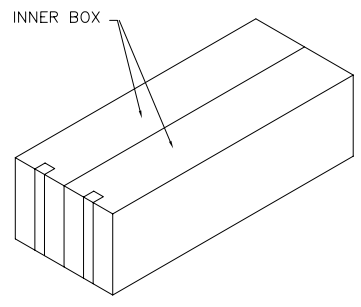

- NOTES:
- MATERIAL:
    - 1.1 TUBE: PVC
    - 1.2 SHIPPING CARTON: CORRUGATED FIBERBOARD
  - DIMENSION:
    - 2.1 TUBE: L=560, W=17.8, H=27.4
    - 2.2 SHIPPING CARTON: L=600, W=245, H=195
  - QUANTITY:
    - 3.1 PRIMARY PACKING: 17 PCS/TUBE
    - 3.2 SECONDARY PACKING: 25 TUBE/BOX
    - 3.3 THIRD PACKING: 2 BOX/CARTON(850PCS)
  - CARTON WEIGHT:
    - 4.1 NET WEIGHT: 8.7 Kg (W/O SCREWLOCK)
    - 4.2 GROSS WEIGHT: 9.7 Kg (W/O SCREWLOCK)

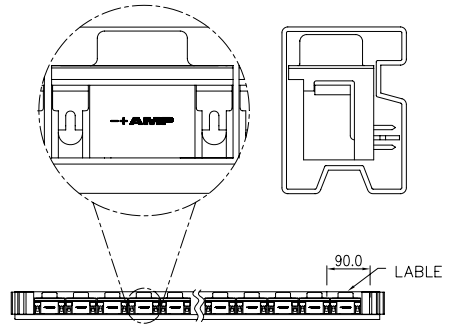
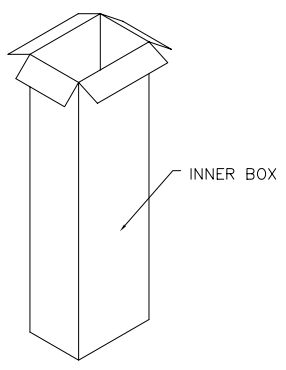
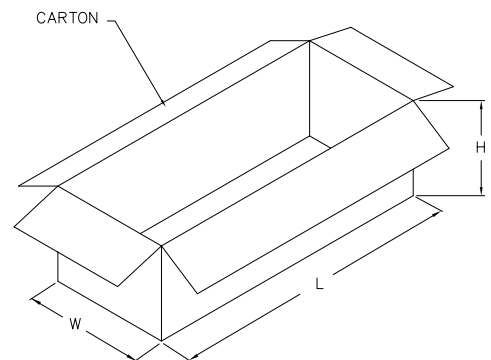

THIS DRAWING IS A CONTROLLED DOCUMENT.		DWN	Tyco Electronics Corporation	
		CHK	Taipei, Taiwan	
DIMENSIONS: MM		APVD	NAME	
TOLERANCES UNLESS OTHERWISE SPECIFIED: 0 PLC ± 1 PLC ± 2 PLC ± 3 PLC ± 4 PLC ± ANGLES ±		PRODUCT SPEC	RECEPTACLE ASSY, SIZE 1, 15 POSITION, RIGHT ANGLE, THROUGH HOLE	
MATERIAL		APPLICATION SPEC	SIZE	RESTRICTED TO
FINISH		WEIGHT	CAGE CODE	DRAWING NO
		CUSTOMER DRAWING	A300779	C=1734530
		SCALE	SHEET	REV
			3 of 4	B

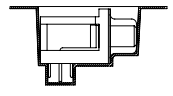
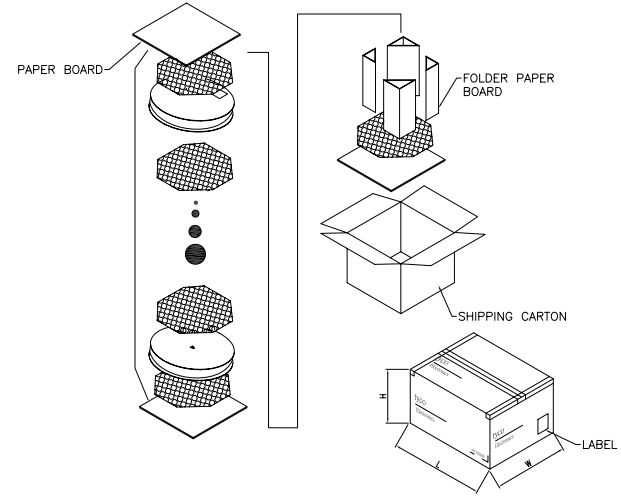
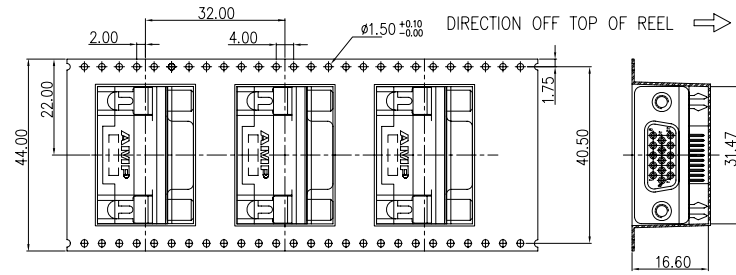
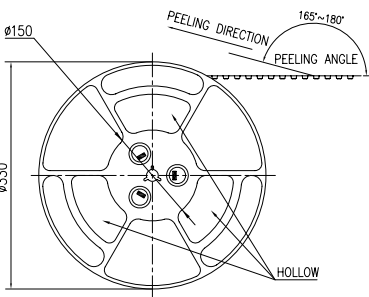
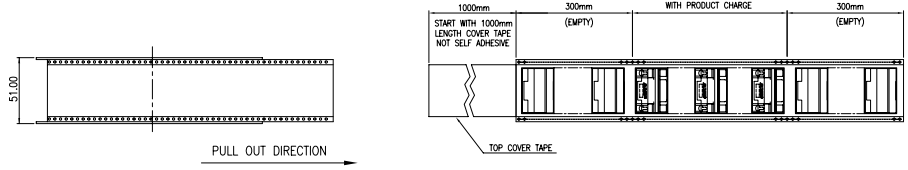

THIS DRAWING IS A CONTROLLED DOCUMENT.

DIMENSIONS:	TOLERANCES UNLESS OTHERWISE SPECIFIED:
MM	
	0 PLC ±
	1 PLC ±
	2 PLC ±
	3 PLC ±
	4 PLC ±
	R/C ANGLES ±
MATERIAL	FINISH

PRODUCT TYPE	PCS/REEL	REEL/CARTON	TOTAL(PCS)	CTN SIZE (CM)	NW(Kg)	GW(Kg)
D-SUB H/D 15P	100	6	600	360X360X350	5.4	5.9
DWN						
CHK						
APVD						
PRODUCT SPEC	NAME: Tyco Electronics Corporation, Taipei, Taiwan					
APPLICATION SPEC	RECEPTACLE ASSY, SIZE 1, 15 POSITION, RIGHT ANGLE, THROUGH HOLE					
WEIGHT	SIZE: A3	CAGE CODE: 00779	DRAWING NO: C=1734530	RESTRICTED TO		
CUSTOMER DRAWING	SCALE	SHEET	4 of 4	REV	B	