

THIS DRAWING IS UNPUBLISHED. RELEASED FOR PUBLICATION
 © COPYRIGHT BY TYCO ELECTRONICS CORPORATION. ALL RIGHTS RESERVED.

LOC	DIST	REVISIONS			
P	LTR	DESCRIPTION	DATE	DWN	APVD
DW	-	A	REVISED (ECR-10-023125)	10NOV10	JL WK

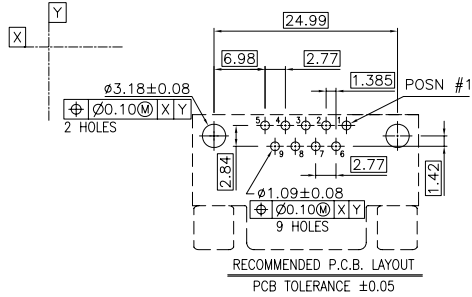
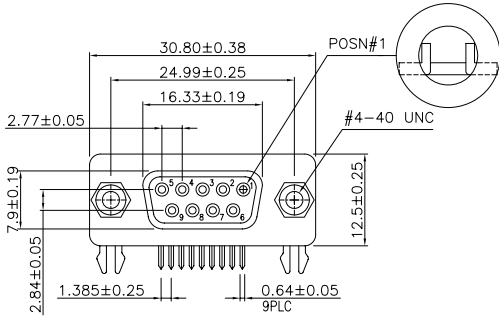

- NOTES:
- MATERIAL:
 - HOUSING: NY9T WITH 30% G.F. UL 94V-0, COLOR: BLACK
 - CONTACTS: PHOSPHOR BRONZE
 - SHELL: SPOC
 - BOARDLOCKS: BRASS
 - RIVET: BRASS
 - SCREWLOCKS: BRASS, THREAD LENGTH OF SCREW: 6.0 MIN.
 - FINISH:
 - CONTACT:
 - GOLD PLATING ON CONTACT AREA. (SEE TABLE)
 - 2.54µm[100u"] MIN. MATTE-TIN PLATING ON SOLDER TAIL,
 - 1.27µm[50u"] MIN. NICKEL UNDERPLATED ON ENTIRE CONTACT.
 - BOARDLOCK:
 - 2.54µm[100u"] MIN. MATTE-TIN PLATING OVER
 - 1.27µm[50u"] MIN. NICKEL UNDERPLATED ON ENTIRE CONTACT.
 - SHELL: NICKEL PLATED
 - RIVET: NICKEL PLATED
 - SCREWLOCKS: NICKEL PLATED
 - NET WEIGHT: 8.9 gram/PC.
 - THREADED INSERTS AND SCREWLOCKS MUST WITHSTAND 6 IN-LBS TORQUE.
 - DAET CODE: YYWW
 - REFLOW SOLDER CAPABLE TO 260°C PER TE SPEC. 109-201, CONDITION B.

0.38µm[15u"]	1734354-2
GOLD-FLASH	1734354-1
CONTACT FINISH MIN.	PART NO.

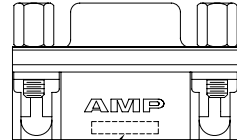
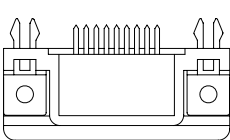
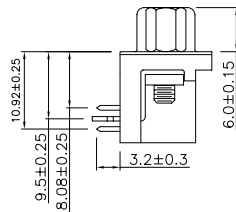
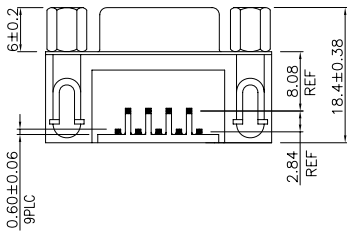

DIMENSIONS:		TOLERANCES UNLESS OTHERWISE SPECIFIED:		THIS DRAWING IS A CONTROLLED DOCUMENT.		Tyco Electronics Corporation	
MM				DWN	DATE	Tyco Electronics Corporation Taipei, Taiwan	
0 PLC	± -	1 PLC	± 0.38	J. LEE	17NOV2008	RECEPTACLE ASSEMBLY, 9 POSN, RIGHT ANGLE, 8.08mm[0.318in] SERIES, AMPLIMITE, WITH SCREWLOCKS	
1 PLC	± 0.25	2 PLC	± 0.15	S. HOU	17NOV2006	QUALIFICATION TEST REPORT	
2 PLC	± -	3 PLC	± -	W. J. KE	17NOV2006	108-57541	
3 PLC	± -	4 PLC	± -	APVD		501-57623	
4 PLC	± -	ANGLES	± -	PRODUCT SPEC		SIZE CAGE CODE DRAWING NO	
MATERIAL		FINISH		WEIGHT		RESTRICTED TO	
SEE NOTE		SEE NOTE		SEE NOTE		A3 00779 ©=1734354	
CUSTOMER DRAWING						SCALE	SHEET 1 of 2 REV A

4

3

2

1

THIS DRAWING IS UNPUBLISHED. RELEASED FOR PUBLICATION
 © COPYRIGHT BY TYCO ELECTRONICS CORPORATION. ALL RIGHTS RESERVED.

LOC	DIST	REVISIONS			
P	LTR	DESCRIPTION	DATE	DWN	APVD
		SEE SHEET 1.			

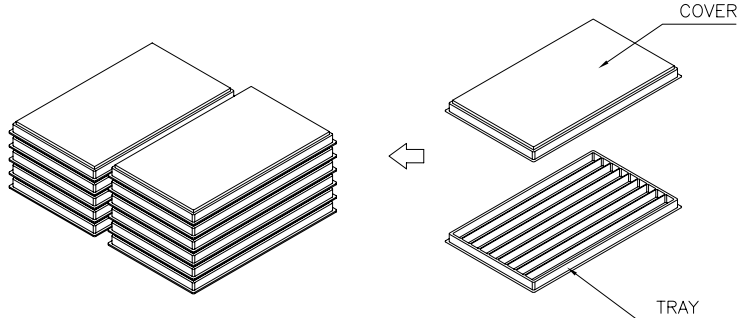

NOTES:

1. MATERIAL:
 - 1.1 TRAY: PVC
 - 1.2 SHIPPING CARTON: CORRUGATED FIBERBOARD
2. DIMENSION:
 - 2.1 TRAY: L=306, W=217, H=15.8
 - 2.2 SHIPPING CARTON: L=440, W=321, H=153
3. QUANTITY:
 - 3.1 PRIMARY PACKING: 90 PCS/TRAY
 - 3.2 SECONDARY PACKING: 11 TRAY/CARTON(990PCS)
4. CARTON WEIGHT:
 - 4.1 NET WEIGHT: 8.9 KG
 - 4.2 GROSS WEIGHT: 9.9 KG

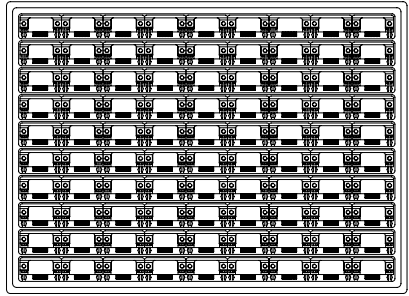
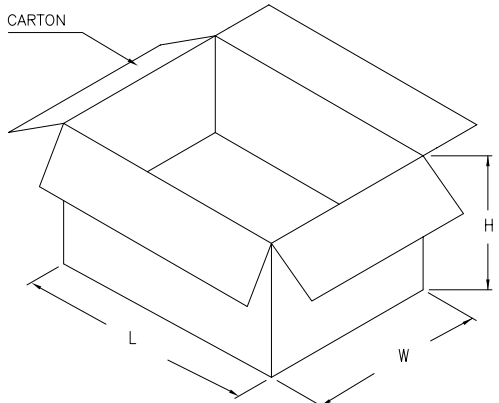

THIS DRAWING IS A CONTROLLED DOCUMENT.		DWN J. LEE 17NOV2006	Tyco Electronics Corporation Taipei, Taiwan
DIMENSIONS: MM		CHK S. HOU 17NOV2006	
		APVD W. J. KE 17NOV2006	NAME RECEPTACLE ASSEMBLY, 9 POSN, RIGHT ANGLE, 8.08mm[0.318in] SERIES, AMPLIMITE, WITH SCREWLOCKS
TOLERANCES UNLESS OTHERWISE SPECIFIED:		PRODUCT SPEC	
0 PLC ± 1 PLC ± 2 PLC ± 3 PLC ± 4 PLC ± ANGLES ±		APPLICATION SPEC	
MATERIAL		WEIGHT	
FINISH		SIZE CAGE CODE DRAWING NO A3 00779 C=1734354	
		RESTRICTED TO	
		CUSTOMER DRAWING	
		SCALE	SHEET 2 OF 2 REV A