

THIS DRAWING IS UNPUBLISHED. RELEASED FOR PUBLICATION
 © COPYRIGHT BY TYCO ELECTRONICS CORPORATION. ALL RIGHTS RESERVED.

LOC	DIST	REVISIONS			
P	LTR	DESCRIPTION	DATE	DWN	APVD
	A	REVISED (ECR-08-024310)	06NOV08	B.W	S.C

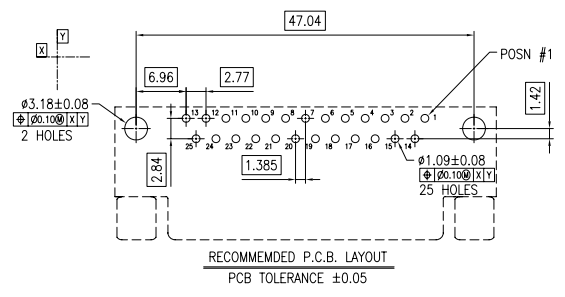
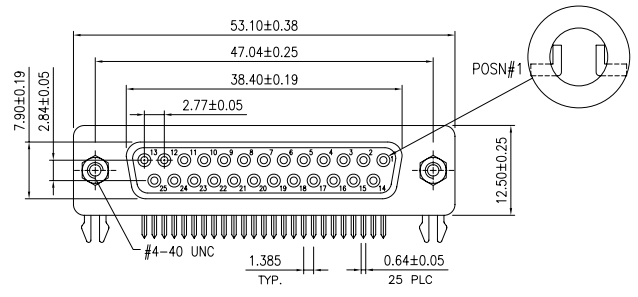

- NOTES:
- MATERIAL:
 - HOUSING: PBT WITH 30% G.F., UL 94V-0, COLOUR: BLACK
 - CONTACTS: PHOSPHOR BRONZE
 - SHELL: SPCC
 - BOARDLOCKS: BRASS
 - RIVET: BRASS
 - SCREWLOCKS: BRASS, SCREW THREAD LENGTH: 6.0 MIN.
 - FINISH:
 - CONTACT: (SEE TABLE)
GOLD PLATING ON CONTACT AREA
2.54um[100u"] MIN. MATTE-TIN ON SOLDER TAIL,
1.27um[50u"] MIN. NICKEL UNDERPLATED ON ENTIRE CONTACT.
 - BOARDLOCK:
2.54um[100u"] MIN. MATTE-TIN OVER 1.27um[50u"] MIN.
NICKEL UNDERPLATED ON ENTIRE CONTACT.
 - SHELL: NICKEL PLATED
 - RIVET: NICKEL PLATED
 - SCREWLOCKS: NICKEL PLATED
 - NET WEIGHT: 14.1 gram/pc
 - THREADED INSERTS AND SCREWLOCKS MUST WITHSTAND 6 IN-LBS TORQUE.
 - DATE CODE: YYWW
 - WAVE SOLDER CAPABLE TO 265°C PER TE SPEC. 109-202, CONDITION B.

OBSOLETE	0.38um[15u"]	1734349-2
	GOLD-FLASH	1734349-1
	CONTACT FINISH MIN.	PART NO.

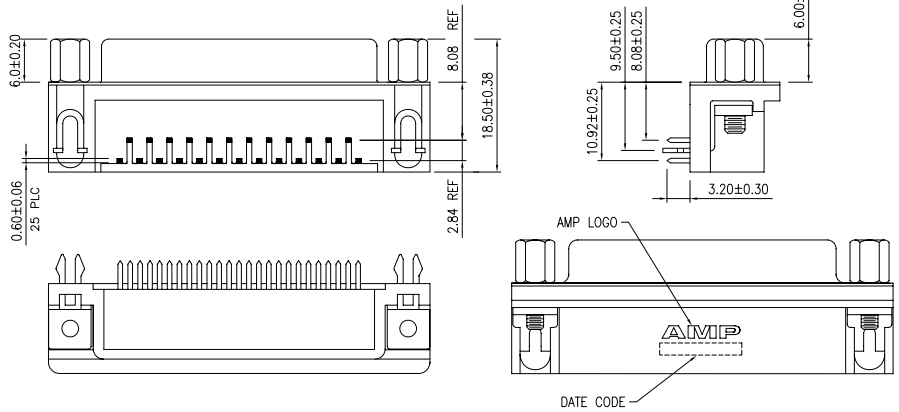

THIS DRAWING IS A CONTROLLED DOCUMENT.		DWN J. LEE 17NOV2006	Tyco Electronics Corporation Taipei, Taiwan	
DIMENSIONS: MM		CHK S. HOU 17NOV2006	NAME RECEPTACLE ASSEMBLY, 25 POSN, RIGHT ANGLE, 8.08mm[0.318in]	
TOLERANCES UNLESS OTHERWISE SPECIFIED: 0 PLC ± - 1 PLC ± 0.38 2 PLC ± 0.25 3 PLC ± 0.15 4 PLC ± - ANGLES ± -		APVD W. J. KE 17NOV2006	PRODUCT SPEC 108-57541	
MATERIAL SEE NOTE		QUALIFICATION TEST REPORT 501-57623	SIZE A3	CAGE CODE 00779
FINISH SEE NOTE		WEIGHT SEE NOTE	DRAWING NO C=1734349	RESTRICTED TO -
CUSTOMER DRAWING			SCALE -	SHEET 1 of 2

4

3

2

1

THIS DRAWING IS UNPUBLISHED. RELEASED FOR PUBLICATION
 © COPYRIGHT BY TYCO ELECTRONICS CORPORATION. ALL RIGHTS RESERVED.

LOC		DIST		REVISIONS			
P	LTR	DESCRIPTION	DATE	DWN	APVD		
		SEE SHEET 1.					

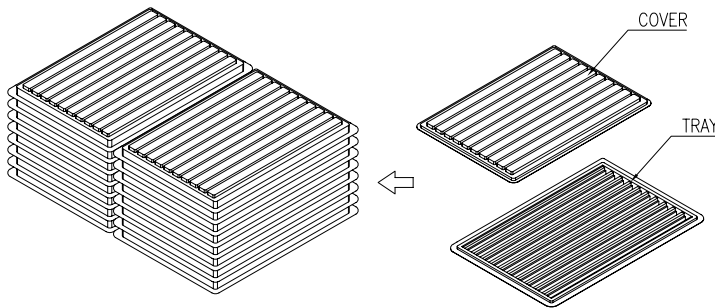

- NOTES:
- MATERIAL:
 - 1.1 TRAY: PVC
 - 1.2 SHIPPING CARTON: CORRUGATED FIBERBOARD
 - DIMENSION:
 - 2.1 TRAY: L=306, W=217, H=15
 - 2.2 SHIPPING CARTON: L=440, W=321, H=210
 - QUANTITY:
 - 3.1 PRIMARY PACKING: 50 PCS/TRAY
 - 3.2 SECONDARY PACKING: 16 TRAY/CARTON (800PCS)
 - CARTON WEIGHT:
 - 4.1 NET WEIGHT: 11.3 KG
 - 4.2 GROSS WEIGHT: 12.8 KG

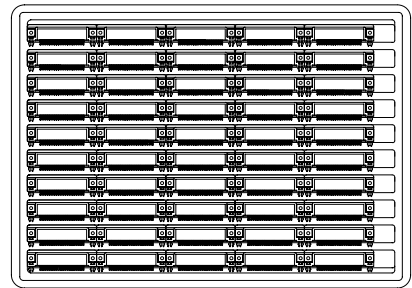
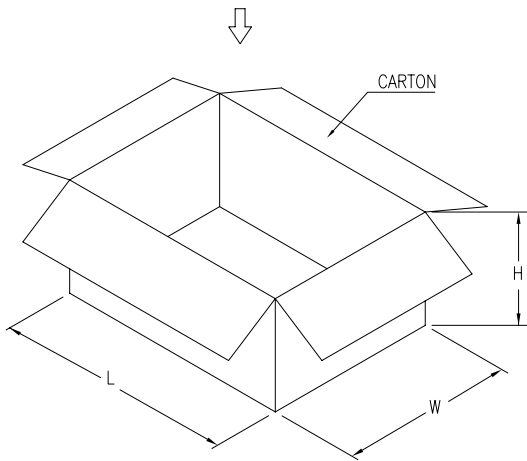

THIS DRAWING IS A CONTROLLED DOCUMENT.		DWN	Tyco Electronics Corporation	
		CHK	Taipei, Taiwan	
DIMENSIONS: MM		APVD	NAME	
0 PLC ± - 1 PLC ± - 2 PLC ± - 3 PLC ± - 4 PLC ± - ANGLES ± -		PRODUCT SPEC APPLICATION SPEC WEIGHT A3 00779 C=1734349		
MATERIAL		SIZE CAGE CODE DRAWING NO		RESTRICTED TO
FINISH		A3 00779 C=1734349		
		CUSTOMER DRAWING		SCALE SHEET 2 of 2 REV A