

THIS DRAWING IS UNPUBLISHED. RELEASED FOR PUBLICATION  
 © COPYRIGHT BY TYCO ELECTRONICS CORPORATION. ALL RIGHTS RESERVED.

LOC		DIST		REVISIONS			
P	LTR	DESCRIPTION		DATE	DWN	APVD	
	A	REVISED (ECR-08-024310)		06NOV08	B.W	S.C	

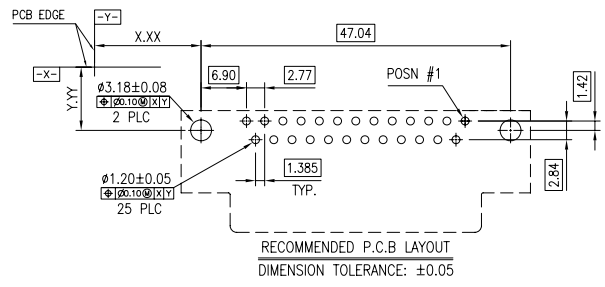

- NOTES:
- MATERIAL:
    - HOUSING: PBT OR NY9T, UL 94V-0 RATED, COLOR: SEE TABLE
    - CONTACTS: PHOSPHOR BRONZE
    - SHELL: SPCC
    - BOARDLOCKS: BRASS
    - RIVET: BRASS
  - FINISH:
    - CONTACT:
      - GOLD PLATING ON CONTACT AREA. (SEE TABLE)
      - 100µ" MIN. MATTE TIN PLATING ON SOLDER TAIL AREA,
      - 50µ" MIN. NICKEL UNDERPLATED OVERALL,
    - BOARDLOCK:
      - 100µ" MIN. MATTE TIN PLATING
      - 50µ" MIN. NICKEL UNDERPLATED OVERALL,
    - SHELL: NICKEL PLATING OVERALL
    - RIVET: NICKEL PLATING OVERALL
  - RECOMMENDED PCB THICKNESS: 1.6 mm
  - WAVE SOLDER CAPABLE TO 265°C, PER TE SPEC. 109-202, CONDITION B.
  - THREADED INSERTS MUST WITHSTAND 6 IN-LBS TORQUE.

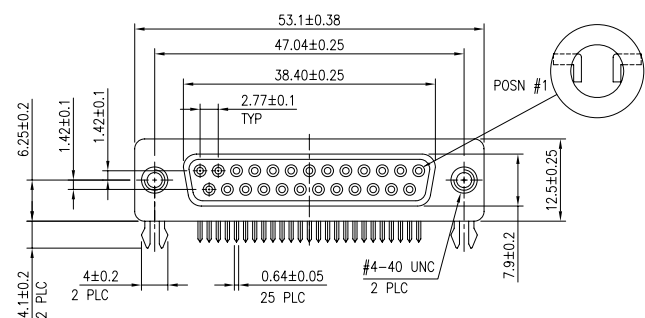
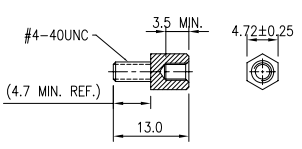
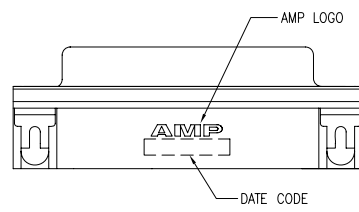
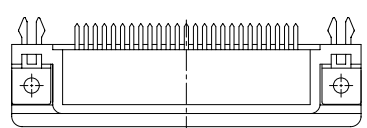
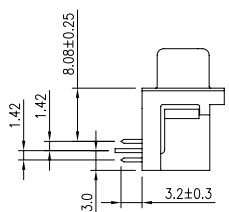
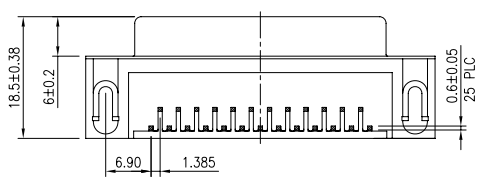

THIS PRODUCT EQUIPPED WITH NO SCREW  
 RECOMMENDED OUTSOURCING SCREW TYPE

OBsolete	BURGUNDY 235C	NY9T	15µ"	2-	-6
		PBT	G/F	2-	-5
			15µ"	2-	-1
			G/F	2-	-0
		NY9T	15µ"	1-	-2
			G/F	1-	-1
		PBT	15µ"		-2
			G/F		-1
					1734350-1
		COLOR	HSG MATERIAL	COLD FINISH	PART NO.

THIS DRAWING IS A CONTROLLED DOCUMENT.

DWN J. LEE 09MAR2007	09MAR2007	Tyco Electronics Corporation Taipei, Taiwan	
CHK S. HOU 09MAR2007	09MAR2007	Tyco Electronics	
APVD W. J. KE 09MAR2007	09MAR2007	NAME AMPLIMITE 8.08mm[0.318in] SERIES, R/A, RCPT, 25 POS	
PRODUCT SPEC 108-57541	QUALIFICATION TEST REPORT 501-57623	SIZE A3	CAGE CODE 00779
MATERIAL SEE NOTE	FINISH SEE NOTE	DRAWING NO C=1734350	RESTRICTED TO REV A
CUSTOMER DRAWING		SCALE	SHEET 1 of 2

4

3

2

1

THIS DRAWING IS UNPUBLISHED. RELEASED FOR PUBLICATION  
 © COPYRIGHT BY TYCO ELECTRONICS CORPORATION. ALL RIGHTS RESERVED.

LOC	DIST	REVISIONS			
P	LTR	DESCRIPTION	DATE	DWN	APVD
		SEE SHEET 1.			

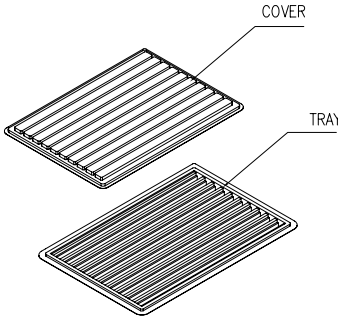
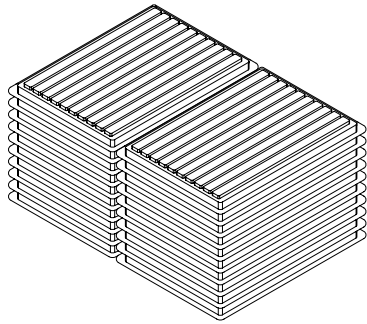

- NOTES:
- MATERIAL:
    - 1.1 TRAY: PVC
    - 1.2 SHIPPING CARTON: CORRUGATED FIBERBOARD
  - DIMENSION:
    - 2.1 TRAY: L=306, W=217, H=15
    - 2.2 SHIPPING CARTON: L=440, W=321, H=210
  - QUANTITY:
    - 3.1 PRIMARY PACKING: 50 PCS/TRAY
    - 3.2 THIRD PACKING: 20 TRAY/CARTON(1,000PCS)
  - WEIGHT:
    - 4.1 NET WEIGHT: 7.0 Kg
    - 4.2 GROSS WEIGHT: 8.0 Kg

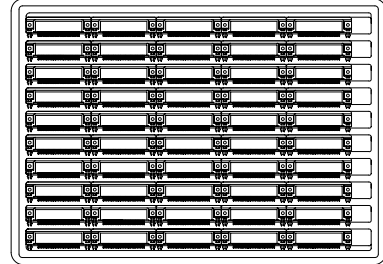
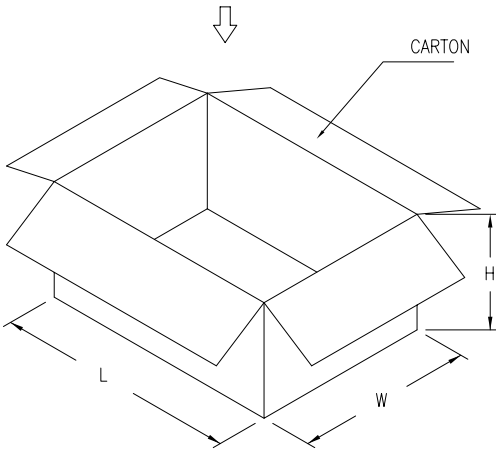

THIS DRAWING IS A CONTROLLED DOCUMENT.		DWN	Tyco Electronics Corporation Taipei, Taiwan	
DIMENSIONS: MM		CHK	NAME	
TOLERANCES UNLESS OTHERWISE SPECIFIED: 0 PLC ±.05 1 PLC ±.05 2 PLC ±.05 3 PLC ±.05 4 R/C ±.05 ANGLES ±.05 FINISH		APVD	AMPLIMITE 8.08mm[0.318in] SERIES, R/A, RCPT, 25 POS	
MATERIAL		PRODUCT SPEC	SIZE	RESTRICTED TO
		APPLICATION SPEC	CAGE CODE	
		WEIGHT	DRAWING NO	
		CUSTOMER DRAWING	A300779	C=1734350
		SCALE	SHEET	REV
			2 of 2	A