

13 12 11 10 9 8 7 6 5 4 3 2 1

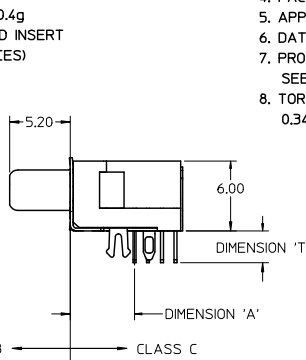

SEE NOTE 7

- NOTES:
- MATERIALS:
HOUSING: HIGH TEMPERATURE THERMOPLASTIC, UL94 V-0, COLOR:BLACK
TAIL ALIGNER: HIGH TEMPERATURE THERMOPLASTIC,
TERMINAL: HIGH PERFORMANCE COPPER ALLOY
BRACKET: BRASS
SHELL: STEEL
INSERT: BRASS
 - FINISHES:
TERMINAL: 0.05-0.25 MICROMETERS GOLD FLASH IN CRITICAL AREA OVER 0.75 MICROMETERS MINIMUM PALLADIUM NICKEL IN CRITICAL AREA. 1.87 MICROMETERS MINIMUM TIN IN SOLDER TAIL AREA OVER 1.25 MICROMETERS MINIMUM NICKEL.
BRACKET: 5.0 MICROMETERS BRIGHT TIN OVER 2.50 MICROMETERS COPPER.
SHIELD: 3.8 MICROMETERS MINIMUM BRIGHT TIN OVER 1.3 MICROMETERS MINIMUM NICKEL OVER COPPER FLASH (OPTIONAL).
INSERT: 2.54 MICROMETERS MINIMUM NICKEL.
 - PART PERFORMS TO MOLEX PRODUCT SPECIFICATION PS-71425-9999.
 - PACKAGE PER PK-71430-0101.
 - APPLICABLE STANDARDS: EIA-3652 AND SFF-8441.
 - DATE CODE: YR/WK PER EIA-476-A.
 - PRODUCT COMPLIES WITH COSMETIC SPECIFICATION PS-45499-002. SEE SIDE VIEW FOR SURFACE CLASSIFICATIONS.
 - TORQUE TO INSTALL SCREWS INTO THREADED INSERTS: 0.34 Nm MAXIMUM.

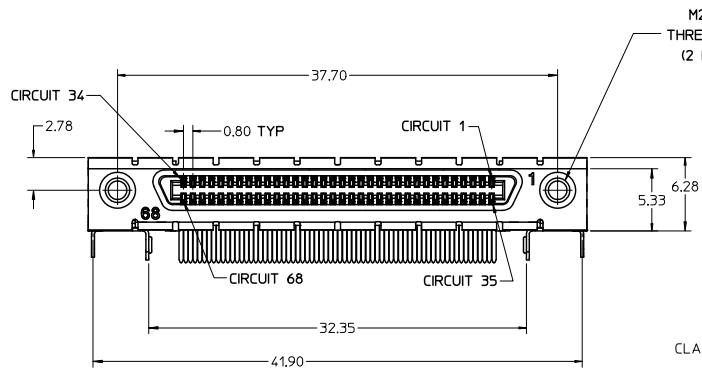
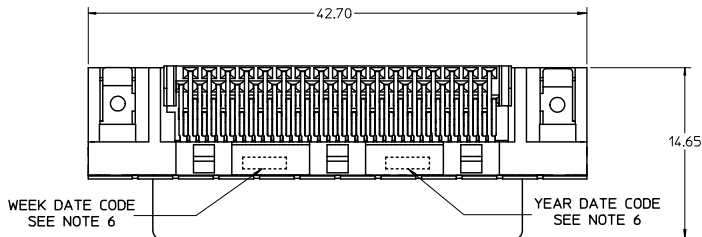
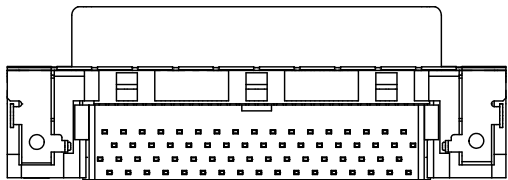
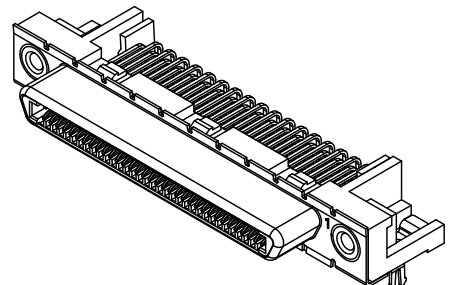

CHANGE PACKAGING EC NO. ICF2010-1970 M DRW:MS (BARRA) 20/10/02/11 CHK:R (BARBER) 11/15/2002 APPR: S (ILLER) 20/10/04/20	QUALITY SYMBOLS ∇=0 ∇=0 ∇=0	GENERAL TOLERANCES (UNLESS SPECIFIED) <table border="1"> <tr> <th></th> <th>mm</th> <th>INCH</th> </tr> <tr> <td>4 PLACES</td> <td>±---</td> <td>±---</td> </tr> <tr> <td>3 PLACES</td> <td>±---</td> <td>±---</td> </tr> <tr> <td>2 PLACES</td> <td>± 0.13</td> <td>±---</td> </tr> <tr> <td>1 PLACE</td> <td>± 0.25</td> <td>±---</td> </tr> </table>		mm	INCH	4 PLACES	±---	±---	3 PLACES	±---	±---	2 PLACES	± 0.13	±---	1 PLACE	± 0.25	±---	DIMENSION STYLE MM ONLY	SCALE 4:1	DESIGN UNITS METRIC	THIRD ANGLE PROJECTION
		mm	INCH																		
	4 PLACES	±---	±---																		
	3 PLACES	±---	±---																		
2 PLACES	± 0.13	±---																			
1 PLACE	± 0.25	±---																			
DRAWN BY KSTILES	DATE 11/14/2002	TITLE VHDCI RIGHT ANGLE ASSEMBLY																			
CHECKED BY KSTILES	DATE 11/15/2002																				
APPROVED BY MBNAKIS	DATE 11/22/2002																				
MATERIAL NO. SEE TABLE		DOCUMENT NO. SD-71430-015		SHEET NO. 1 OF 3																	
DRAFT WHERE APPLICABLE MUST REMAIN WITHIN DIMENSIONS																					
THIS DRAWING CONTAINS INFORMATION THAT IS PROPRIETARY TO MOLEX INCORPORATED AND SHOULD NOT BE USED WITHOUT WRITTEN PERMISSION																					

12 11 10 9 8 7 6 5 4 3 2 1

13 12 11 10 9 8 7 6 5 4 3 2 1

PCB THICKNESS	PART NUMBER	TAIL LENGTH 'T'	ENHANCED GROUND TABS	SCREWLOCKS	TAIL LOC. 'A'	HOLE LOCATION 'B'
1.60	71430-0101	2.08	NO	NONE	5.50	6.50 MAXIMUM
1.60	71430-0007	2.08	NO	LOOSE IN BAGS		
1.60	71430-0005	2.08	YES	NONE		
1.60	71430-0008	2.08	YES	LOOSE IN BAGS		
2.36	71430-0268	2.71	NO	NONE		
2.36	71430-0006	2.71	NO	INSTALLED		
2.36	71430-0004	2.71	YES	NONE		
2.36	71430-0009	2.71	YES	INSTALLED		
2.36	71430-0016	2.71	NO	LOOSE IN BAGS		
2.36	71430-0019	2.71	YES	LOOSE IN BAGS	5.30	6.30 MAXIMUM
2.36	71430-0012	2.71	YES	NONE		
1.60	71430-0013	2.08	YES	NONE		

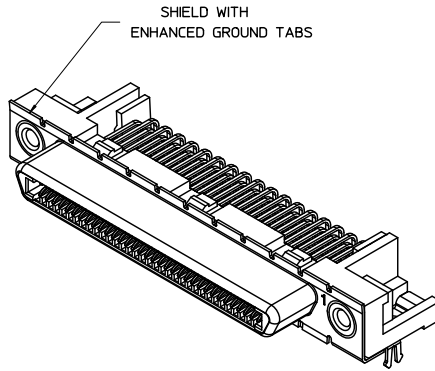
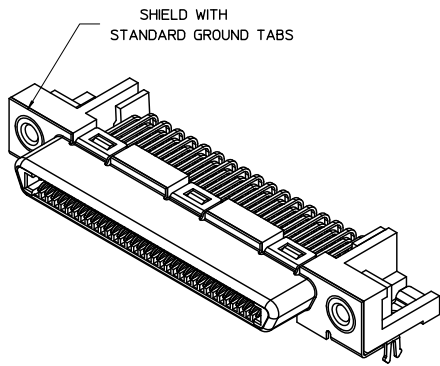

OPTIONAL SCREWLOCK
PART NUMBER 71433-0002

SEE SHEET 1 EIC NO. UEP2010-1970 DRWING: BARRA 20/01/02/15 CHK: BARBER 11/15/2002 APPR: SHTLER 20/01/07/20	QUALITY SYMBOLS	GENERAL TOLERANCES (UNLESS SPECIFIED)	DIMENSION STYLE	SCALE	DESIGN UNITS	THIRD ANGLE PROJECTION
	$\nabla = 0$ $\nabla = 0$ $\nabla = 0$	mm INCH 4 PLACES ± --- ± --- 3 PLACES ± --- ± --- 2 PLACES ± 0.13 ± --- 1 PLACE ± 0.25 ± --- ANGULAR ± 1/2°	MM ONLY	4:1	METRIC	
	DESCRIPTION	DRAFT WHERE APPLICABLE MUST REMAIN WITHIN DIMENSIONS	DRAWN BY DATE KSTILES 11/14/2002 CHECKED BY DATE KSTILES 11/15/2002 APPROVED BY DATE MBNAKIS 11/22/2002	TITLE	VHDCI RIGHT ANGLE ASSEMBLY	
	REV		MATERIAL NO.	SEE TABLE	DOCUMENT NO.	MOLEX INCORPORATED
			SIZE C	THIS DRAWING CONTAINS INFORMATION THAT IS PROPRIETARY TO MOLEX INCORPORATED AND SHOULD NOT BE USED WITHOUT WRITTEN PERMISSION		
					SD-71430-015	SHEET NO. 2 OF 3

12 11 10 9 8 7 6 5 4 3 2 1

13 12 11 10 9 8 7 6 5 4 3 2 1

- NOTES:
1. MATERIALS:
 HOUSING: GLASS FILLED LIQUID CRYSTAL POLYMER (LCP), UL94 V-0, COLOR:BLACK
 TAIL ALIGNER: GLASS FILLED LIQUID CRYSTAL POLYMER (LCP),
 TERMINAL: HIGH PERFORMANCE COPPER ALLOY
 SHIELD: STEEL
 THREADED INSERT: BRASS - LEAD FREE
 2. FINISHES:
 TERMINAL: 0.05-0.25 MICROMETERS GOLD FLASH IN CRITICAL AREA OVER 0.75 MICROMETERS MINIMUM PALLADIUM NICKEL IN CRITICAL AREA, 1.87 MICROMETERS MINIMUM MATTE TIN IN SOLDER TAIL AREA. OVERALL NICKEL UNDERPLATE.
 BRACKET: 5.0 MICROMETERS MINIMUM BRIGHT TIN OVER A COPPER UNDERPLATE.
 SHIELD: 3.8 MICROMETERS MINIMUM BRIGHT TIN OVER 1.3 MICROMETERS MINIMUM NICKEL OVER COPPER FLASH (OPTIONAL).
 THREADED INSERT: 2.54 MICROMETERS MINIMUM NICKEL.
 3. PART CONFORMS TO MOLEX PRODUCT SPECIFICATION PS-71425-9999.
 4. PRODUCT IS PACKAGED PER PK-71430-0101.
 5. APPLICABLE STANDARDS: EIA-3652 AND SFF-8441.
 6. DATE CODE: YR/WK PER EIA-476-A.
 7. PRODUCT COMPLIES WITH COSMETIC SPECIFICATION PS-45499-002. SEE SIDE VIEW FOR SURFACE CLASSIFICATIONS.
 8. TORQUE TO INSTALL SCREWLOCKS INTO THREADED INSERTS: 0.34 Nm MAXIMUM.

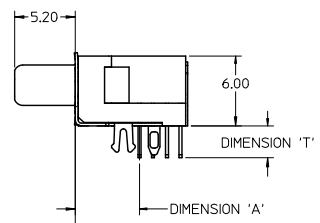
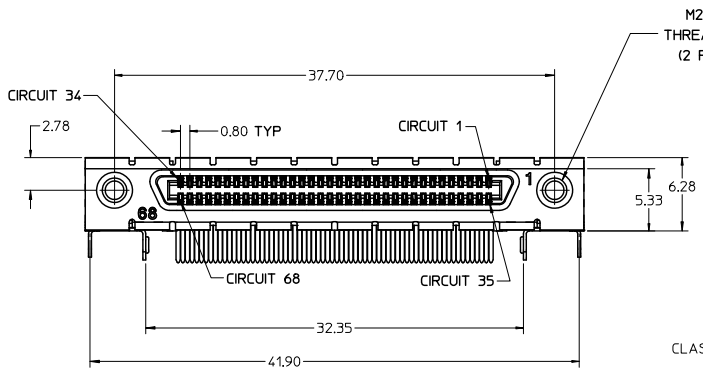
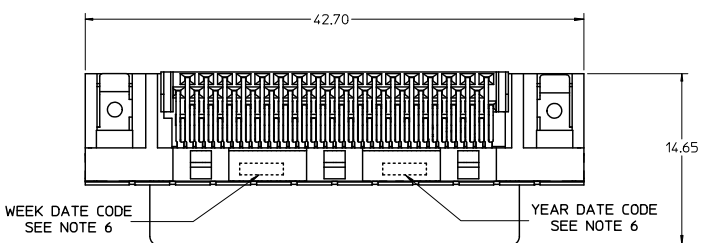

CLASS B CLASS C
SEE NOTE 7

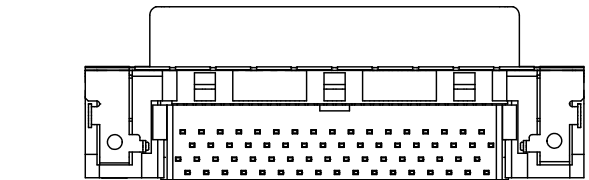
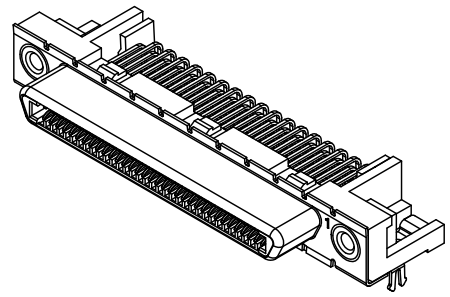

ALL ASSEMBLIES ON THIS DRAWING ARE LEAD-FREE

INITIAL RELEASE EC NO. LCP2011-2476 DRAWN BY: BBARKER 2011/02/17 CHECKED BY: CHRIS SMILLER APPR: SMILLER 2011/02/25 DESCRIPTION:	QUALITY SYMBOLS	GENERAL TOLERANCES (UNLESS SPECIFIED)	DIMENSION STYLE	SCALE	DESIGN UNITS	THIRD ANGLE PROJECTION
	▽=0	4 PLACES ±--- ±---	MM ONLY	4:1	METRIC	⊙
	▽=0	3 PLACES ±--- ±---	DRAWN BY: BBARKER DATE: 2011/02/17	TITLE: VHDCI RIGHT ANGLE ASSEMBLY		
	▽=0	2 PLACES ±0.13 ±---	CHECKED BY: SMILLER DATE: 2011/02/25	APPROVED BY: SMILLER DATE: 2011/02/25	MOLEX INCORPORATED	
		1 PLACE ±0.25 ±---	ANGULAR ±1/2°	MATERIAL NO. SEE TABLE	DOCUMENT NO. SD-71430-3000	SHEET NO. 1 OF 3
		DRAFT WHERE APPLICABLE MUST REMAIN WITHIN DIMENSIONS	SIZE C	THIS DRAWING CONTAINS INFORMATION THAT IS PROPRIETARY TO MOLEX INCORPORATED AND SHOULD NOT BE USED WITHOUT WRITTEN PERMISSION		

12 11 10 9 8 7 6 5 4 3 2 1

13 12 11 10 9 8 7 6 5 4 3 2 1

PCB THICKNESS	PART NUMBER	TAIL LENGTH "T" +0.50/-0.25	ENHANCED GROUND TABS	SCREWLOCKS (SEE GUIDELINE FOR CHOOSING A SCREWLOCK ON SHEET 3)	TAIL LOCATION "A"	PCB HOLE LOCATION "B"
1.60		2.08	NO	NONE	5.50	6.50 MAXIMUM
1.60		2.08	NO	71433-2002 LOOSE IN BAGS		
1.60		2.08	YES	NONE		
1.60		2.08	YES	71433-2002 LOOSE IN BAGS		
2.36		2.71	NO	NONE		
2.36		2.71	NO	71433-2002 INSTALLED		
2.36		2.71	YES	NONE		
2.36		2.71	YES	71433-2002 INSTALLED		
2.36		2.71	NO	71433-2002 LOOSE IN BAGS		
2.36	71430-3019	2.71	YES	71433-2002 LOOSE IN BAGS		
2.36		2.71	YES	NONE	5.30	6.30 MAXIMUM
1.60		2.08	YES	NONE		

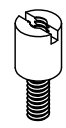
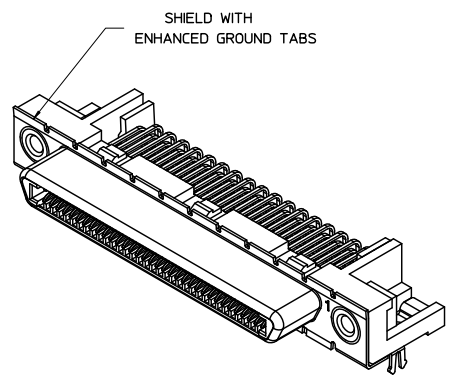
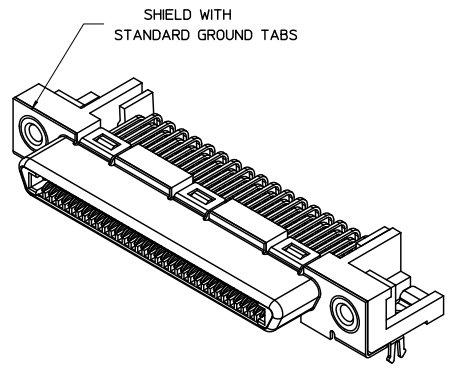

OPTIONAL SCREWLOCK
PART NUMBER 71433-2002 SHOWN
(SEE GUIDELINE FOR CHOOSING
A SCREWLOCK ON SHEET 3)

SEE SHEET 1 EIC NO. UCF2011-2/76 DRAWN BY: BBARKER 2011/02/17 CHECKED BY: SMILLER APPR: SMILLER 2011/02/25 REV: A	QUALITY SYMBOLS	GENERAL TOLERANCES (UNLESS SPECIFIED)	DIMENSION STYLE	SCALE	DESIGN UNITS	THIRD ANGLE PROJECTION
	$\nabla = 0$ $\nabla = 0$ $\nabla = 0$	mm INCH 4 PLACES ± --- ± --- 3 PLACES ± --- ± --- 2 PLACES ± 0.13 ± --- 1 PLACE ± 0.25 ± --- ANGULAR ± 1/2°	MM ONLY	4:1	METRIC	TITLE: VHDCI RIGHT ANGLE ASSEMBLY APPROVED BY: SMILLER DATE: 2011/02/25 MATERIAL NO.: SEE TABLE DOCUMENT NO.: SD-71430-3000
	DRAFT WHERE APPLICABLE MUST REMAIN WITHIN DIMENSIONS	SEE TABLE	MOLEX INCORPORATED THIS DRAWING CONTAINS INFORMATION THAT IS PROPRIETARY TO MOLEX INCORPORATED AND SHOULD NOT BE USED WITHOUT WRITTEN PERMISSION			
			SIZE C			SHEET NO. 2 OF 3

12 11 10 9 8 7 6 5 4 3 2 1

