

This document is the property of Amphenol Corporation and is delivered on the express condition that it is not to be distributed, reproduced or used, in whole or in part, for manufacturing or sales for anyone other than Amphenol Corporation without the prior consent, in that no right is granted to disclose or to use any information in this document.

REVISIONS				
SYM	ECN	DESCRIPTION	DATE	APPROVED
A	HK	INITIAL RELEASE	03/26/01	Y.M.LEE

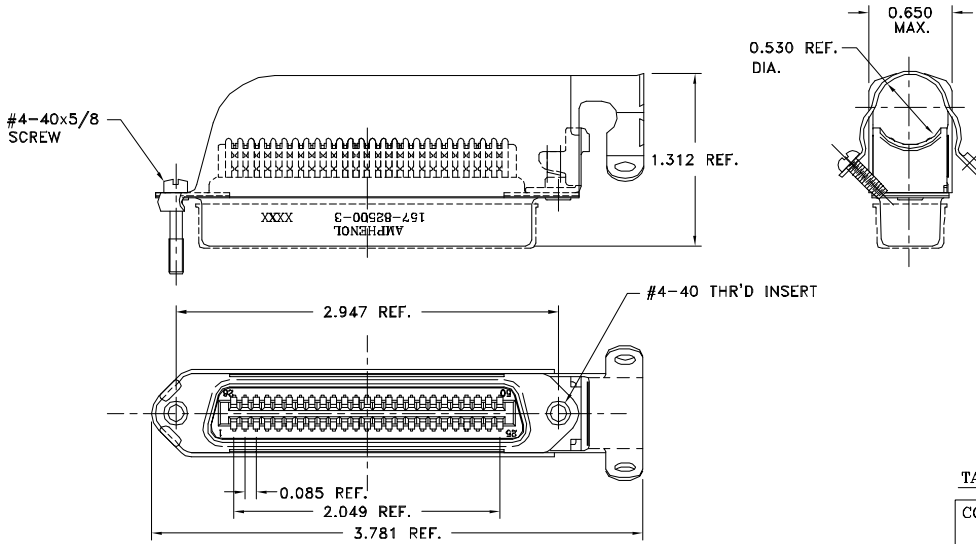

TABLE 1

CONNECTOR SIZES	AVERAGE MATING FORCE (POUNDS)
14	5
24	8
36	12
50	15
64	19

SPECIFICATIONS:

- 1) INSULATION DISPLACEMENT CONTACTS: TO ACCOMMODATE 24-26 AWG SOLID AND 28-28 STRANDED CONNECTOR WIRES.
- 2) DIELECTRIC: PBT GLASS FIBER RE-INFORCED, UL-94V0
- 3) CONTACT MATERIAL: COPPER ALLOY
- 4) CONTACT: 20 MICRO-INCHES MIN. GOLD MATING AREA: 3-5 MICRO-INCHES GOLD TERMINAL AREA: 50 MICRO-INCHES MIN. NICKEL UNDERPLATING ALL OVER.
- 5) SHELL MATERIAL: ZINC PLATED STEEL WITH CLEAR CHROMATE COATING
- 6) CURRENT CAPACITY: 5 AMPS/CONTACT
- 7) VOLTAGE RATING: 700 VOLTS D.C. AT SEA LEVEL
200 VOLTS D.C. AT 70,000 FEET
- 8) INSULATION RESISTANCE: >5000 M OHM
- 9) DIELECTRIC WITHSTANDING VOLTAGE: 1200 VAC (RMS) AT SEA LEVEL
- 10) CONNECTOR MATING FORCE: REFER TO TABLE 1.
- 11) CONTACT RETENTION FORCE: 2 LBS MAX.
- 12) DURABILITY: 250 CYCLES MIN.
- 13) VIBRATION: NO INTERRUPTIONS < 1u SEC.
- 14) OPERATING TEMPERATURE: -55°C TO +105°C (-67°F TO +221°F)

CUSTOMER INFORMATION DRAWING

ITEM NO	PART OR IDENTIFICATION NO	NOMENCLATURE OR DESCRIPTION	QTY REQ'D
PARTS LIST			
UNLESS OTHERWISE SPECIFIED TOLERANCES		APPROVAL DATE	Amphenol Amphenol East Asia Limited Manufacturing Operation
DRAWN Y.M. LEE 03/26/01		CHECKED Y.M. LEE 03/26/01	
DRAWING FILE: \DRAWING\157\C157825003.DWG		TITLE 50 CONTACT RECEPT. ASSEMBLY RUNNING CABLE 25-50 END 28 & 26 AWG WIRE, DUST COVER	
FOR MATERIALS AND FINISHES SEE NOTES		ANGLE OF PROJECTION	SIZE DRAWING NO. REV.
REMOVE SHARP EDGES			A3 C157-82500-3 B
DIMENSIONS			SCALE NONE SHEET 1 OF 1
U.S. INCHES			
-(METRIC)- -(MM)-			