

LOC	DIST	REVISIONS			
P	LYR	DESCRIPTION	DATE	BY	APPR
-	-	SEE SHEET 1	-	-	-

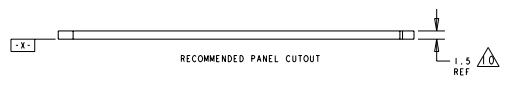
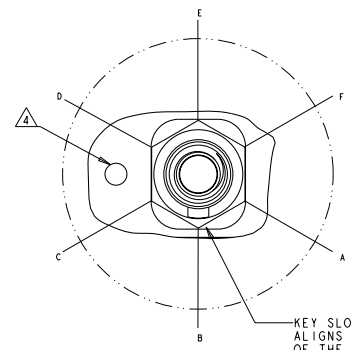
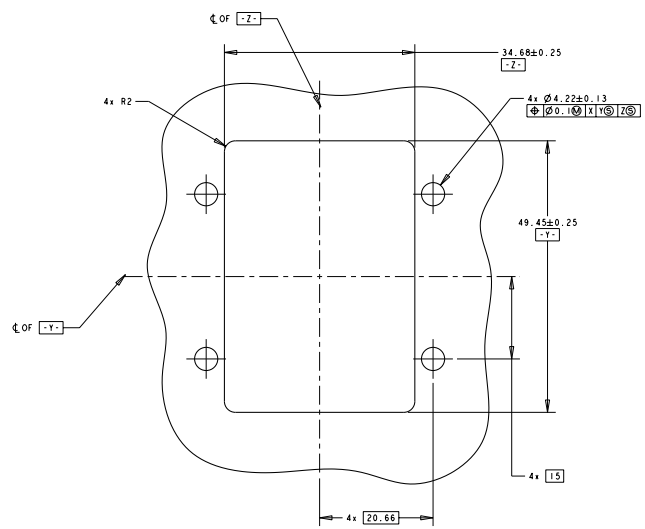

DIMENSIONS: mm		TO BE MADE TO ORDER OPERATING SPECIFICATIONS:		DWN 24MAY2005	Tyco Electronics Harrisburg, PA 17105-3608
OPERATING SPECIFICATIONS:		PRODUCT SPEC		CDR 24MAY2005	
MATERIAL		FINISH		APPR 24MAY2005	NAME RECEPTACLE SHELL KIT, VERTICAL, REAR PANEL MOUNT, WITH A-F JACKNUT, GPRB2
WEIGHT		CUSTOMER DRAWING		SHEET A2	CASE CODE 00779
FINISH		SCALE 1:1		DRAWING NO 1877720	RESTRICTED TO