

This document is the property of Amphenol Corporation and is delivered on the express condition that it is not to be disclosed, reproduced or used in whole or in part, for manufacture or sale by anyone other than Amphenol Corporation without its prior consent, and that no right is granted to disclose or to use any information in this document.

REVISIONS				
SYM	ECN	DESCRIPTION	DATE	APPROVED
A	HK#	PRELIMINARY RELEASE	3/04/03	Y.M.LEE
B	HK#	ADD CHOP OF ROHS	12/14/05	IP

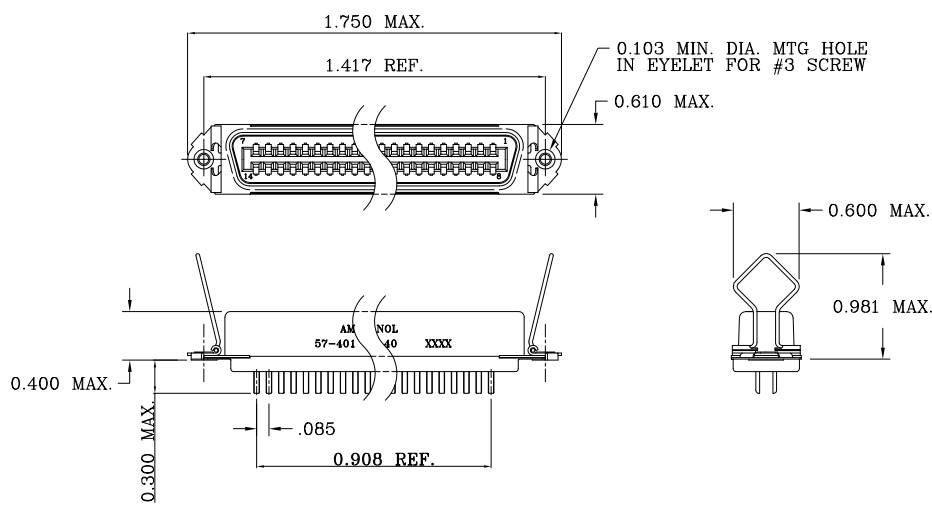

TABLE 1

CONNECTOR SIZES	AVERAGE MATING FORCE (POUNDS)
14	5
24	8
36	12
50	15
64	19

SPECIFICATIONS:

- 1) SOLDER CONTACT: SOLDER CUP CONTACT TO ACCOMMODATE 22-30 AWG SOLID & 24-30 STRANDED CONNECTOR WIRES.
- 2) DIELECTRIC: DIALLY-PHTHALATE PER MIL-M-14F TYPE MDG UL-94V0
- 3) CONTACT MATERIAL: COPPER ALLOY
- 4) CONTACT: 20 MICRO-INCHES MIN. GOLD MATING AREA, GOLD FLASH ON TAIL. 50 MICRO-INCHES MIN. NICKEL UNDERPLATING ALL OVER.
- 5) SHELL MATERIAL: ZINC PLATED STEEL WITH CLEAR CHROMATE COATING
- 6) CURRENT CAPACITY: 5 AMPS/CONTACT
- 7) VOLTAGE RATING: 700 VOLTS D.C. AT SEA LEVEL  
200 VOLTS D.C. AT 70,000 FEET
- 8) INSULATION RESISTANCE: >5000 M OHM
- 9) DIELECTRIC WITHSTANDING VOLTAGE: 1200 VAC (RMS) AT SEA LEVEL
- 10) CONNECTOR MATING FORCE: REFER TO TABLE 1.

- 11) CONTACT RETENTION FORCE: 2 LBS MAX.
- 12) DURABILITY: 250 CYCLES MIN.
- 13) VIBRATION: NO INTERRUPTIONS < 1u SEC.
- 14) OPERATING TEMPERATURE: -55°C TO +105°C  
(-67°F TO +221°F)
- 15) MATERIAL SHOULD BE FULFILLED AMPHENOL SPEC.# SSN001

CUSTOMER INFORMATION DRAWING

ITEM NO.	PART OR IDENTIFICATION NO.	NOMENCLATURE OR DESCRIPTION	QTY REQ'D
PARTS LIST			
UNLESS OTHERWISE SPECIFIED TOLERANCES		APPROVAL	DATE
U.S. METRIC		DRAWN XS.GUO	12/14/05
X +/- .010		CHECKED	
XX +/- .004		CHECKED	
XXX +/- .002			
FRACTIONS +/-			
ANGLES +/- 1°			
FOR MATERIALS AND FINISHES SEE NOTES		DRAWING FILE : /DRAWING/97/C5740140.DWG	TITLE
REMOVE SHARP EDGES		ANGLE OF PROJECTION	14 CONTACT RECEPTACLE ASS'Y MINIATURE RIBBON, SPRING LATCH
DIMENSIONS		SIZE	DRAWING NO.
U.S. INCHES		A3	C57-40140
-(METRIC)		SCALE	NONE
			REV. B
			SHEET 1 OF 1