

REV	DATE	DESCRIPTION	BY	CHK	APP
00					
01		REVISED PER EDD-10-013809			

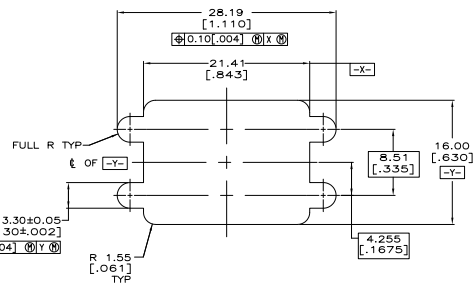
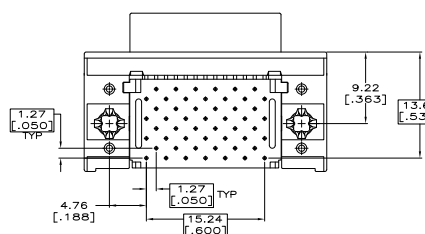
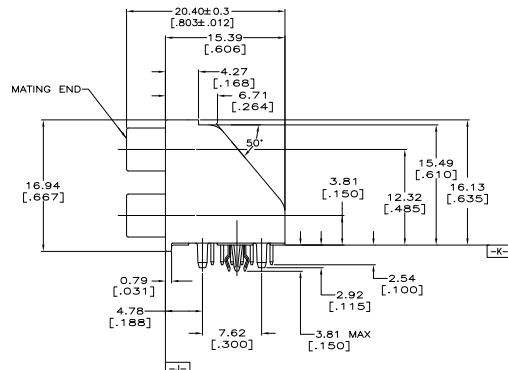
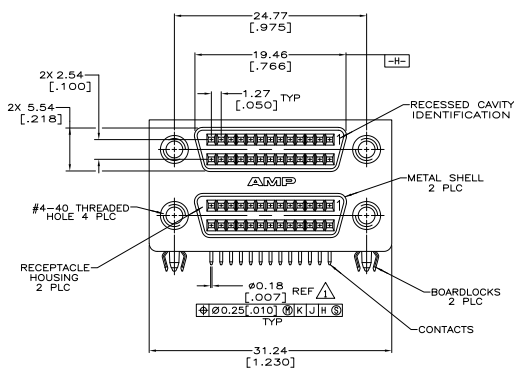
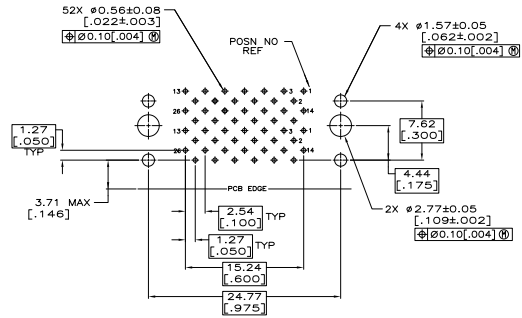
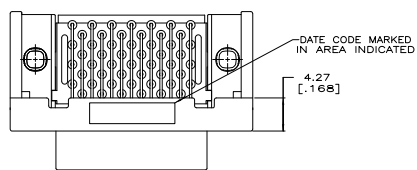

- △ POSITION TOLERANCE APPLIES AT TIP ONLY.
- △ MATERIAL
RECEPTACLE HOUSING: UL 94V-0 RATED LCP, COLOR BLACK
CONTACTS: PHOSPHOR BRONZE
BRACKET: ZINC
METAL SHELL: CARBON STEEL
BOARDLOCKS: COPPER ALLOY.
- △ FINISH
CONTACTS: GOLD FLASH OVER PALLADIUM-NICKEL PLATE, 0.00076 [0.00030] MIN TOTAL ON MATING SURFACES, 0.00038 [0.00150] MIN TIN-LEAD PLATE ON SOLDER-TAILS, 0.00127 [0.00050] MIN NICKEL UNDERPLATE ON ENTIRE CONTACT. -OR- 0.00076 [0.00030] MIN GOLD PLATE ON MATING SURFACES, 0.00038 [0.00150] MIN TIN-LEAD PLATE ON SOLDER-TAILS, 0.00127 [0.00050] MIN NICKEL UNDERPLATE ON ENTIRE CONTACT.
BRACKET: 0.00508-0.01016 [0.00200-0.00400] TIN-LEAD OVER 0.00508-0.00762 [0.00200-0.00300] COPPER.
METAL SHELL: 0.00508-0.01016 [0.00200-0.00400] TIN OVER 0.00127-0.00254 [0.00050-0.00100] COPPER.
BOARDLOCKS: 0.00508-0.01016 [0.00200-0.00400] TIN-LEAD OVER 0.00127-0.00254 [0.00050-0.00100] NICKEL.

786200-1
PART NUMBER

THIS DRAWING IS A CONTROLLED DOCUMENT.		REV	DATE	BY	CHK	APP
		00				
		01				
		02				
		03				
		04				
		05				
		06				
		07				
		08				
		09				
		10				
		11				
		12				
		13				
		14				
		15				
		16				
		17				
		18				
		19				
		20				
		21				
		22				
		23				
		24				
		25				
		26				
		27				
		28				
		29				
		30				
		31				
		32				
		33				
		34				
		35				
		36				
		37				
		38				
		39				
		40				
		41				
		42				
		43				
		44				
		45				
		46				
		47				
		48				
		49				
		50				
		51				
		52				
		53				
		54				
		55				
		56				
		57				
		58				
		59				
		60				
		61				
		62				
		63				
		64				
		65				
		66				
		67				
		68				
		69				
		70				
		71				
		72				
		73				
		74				
		75				
		76				
		77				
		78				
		79				
		80				
		81				
		82				
		83				
		84				
		85				
		86				
		87				
		88				
		89				
		90				
		91				
		92				
		93				
		94				
		95				
		96				
		97				
		98				
		99				
		100				