

REV	DATE	DESCRIPTION	BY	CHK	APP
00					
0		RELEASED PER EC 0513-0440-04	12-07-04	LV	JG

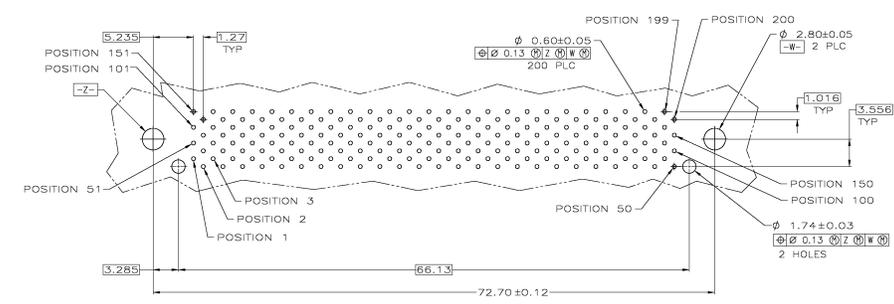

RECOMMENDED PC BOARD MOUNTING DIMENSIONS
 COMPONENT SIDE

- △ HOUSING AND TINE PLATE: POLYESTER, NATURAL.
 CONTACT: COPPER ALLOY.
 SHELL: CARBON STEEL.
 RETENTION LEG AND GUIDE PIN: BRASS.
 PLUG G-PLATE: STAINLESS STEEL.
- △ SHELL: 3.00µm MIN NICKEL OVER 1.30µm MIN COPPER.
 RETENTION LEG: 2.00µm MIN TIN OVER 1.00µm MIN NICKEL.
 GUIDE PIN: NICKEL OVER COPPER.
 CONTACTS: 0.76µm MIN GOLD FOR A LENGTH OF 3.00 MIN FROM MATING END,
 2.54 µm MIN TIN FOR A LENGTH OF 5.70 MIN FROM OPPOSITE END,
 BOTH OVER 1.27µm MIN NICKEL.
- △ CONTACTS 1,2,49,50,51,52,99, AND 100, ARE SEQUENCED TOWARDS MATING FACE.
- △ DATE CODE MAY BE MARKED ON THIS SIDE, IN ONE OF THE LOCATIONS SHOWN.

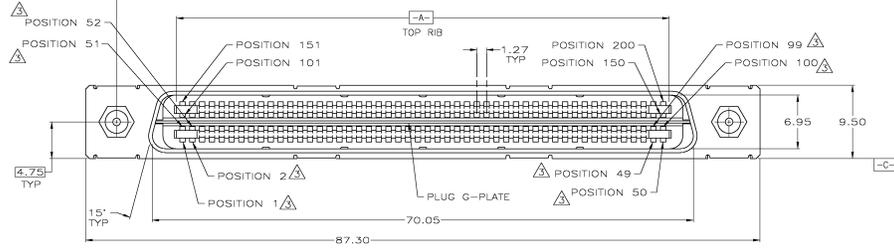
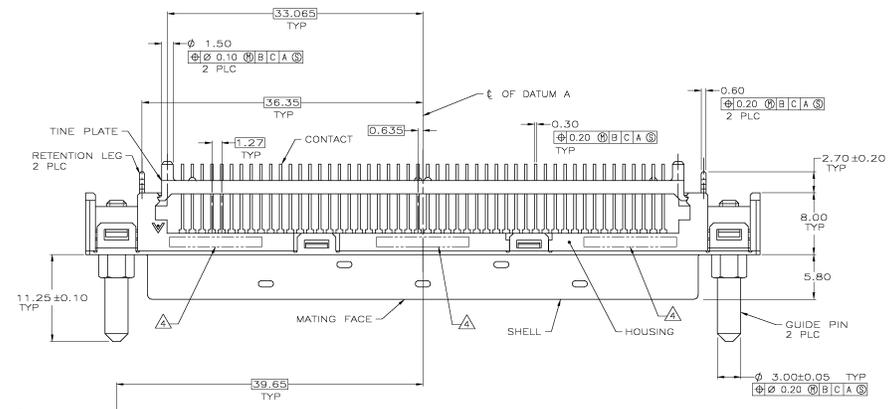
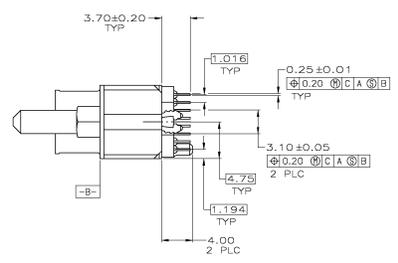

5787859-1
 PART NUMBER

THIS DRAWING IS A CONTROLLED DOCUMENT		DATE: 12-07-04	REV: 00	REVISED BY: JG	DATE: 12-07-04	REV: 00	REVISED BY: JG
DRAWN BY: JG		DESIGNED BY: JG	DATE: 12-07-04	REV: 00	REVISED BY: JG	DATE: 12-07-04	REV: 00
CHECKED BY: JG		DATE: 12-07-04	REV: 00	REVISED BY: JG	DATE: 12-07-04	REV: 00	REVISED BY: JG
MATERIAL: BRASS		WEIGHT: ---	DATE CODE: A1	DATE CODE: 00778	DATE CODE: 5787859	RESTRICTED TO: ---	RESTRICTED TO: ---
CUSTOMER DRAWING		SCALE: 2:1	SHEET: 1	TOTAL SHEETS: 1	REV: 0		