

4

3

2

1

THIS DRAWING IS UNPUBLISHED. RELEASED FOR PUBLICATION  
 © COPYRIGHT - BY TYCO ELECTRONICS CORPORATION. ALL RIGHTS RESERVED.

LOC	DIST	REVISIONS				
P	LTR	DESCRIPTION	DATE	DWN	APVD	
01		REVISE ECR-06-014234	13JUN2006	JL	SH	
A		REVISE ECR-07-020943	04SEP2007	JL	SH	

NOTES:

- MATERIALS  
 HOUSING: THERMOPLASTIC(PBT) WITH GLASS FIBER  
 UL94V-0, BLACK COLOR  
 CONTACT: PHOSPHOR BRONZE  
 SHELL, RIVET AND WASHER: STEEL  
 HEX-SCREWLOCKS: BRASS
- FINISH:  
 CONTACT: 0.381um[15u"] MIN. GOLD PLATING ON CONTACT AREA  
 2.54um[100u"] MIN. MATTE TIN PLATING ON SOLDER TAIL  
 1.27um[50u"] MIN. NICKEL UNDERPLATED ALL OVER  
 SHELL, RIVET, WASHER AND HEX-SCREWLOCKS:  
 2.032[80u"] MIN. NICKEL PLATING
- WAVE SOLDER CAPABLE TO 265°C  
 PER TE SPEC. 109-202, CONDITION B.
- SCREWLOCKS MUST WITHSTAND 6 IN-LBS TORQUE

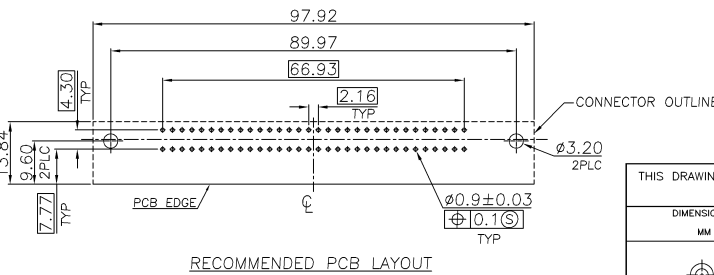
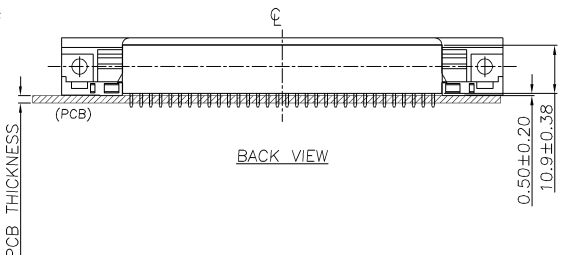
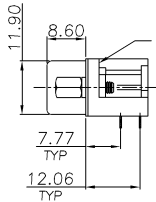
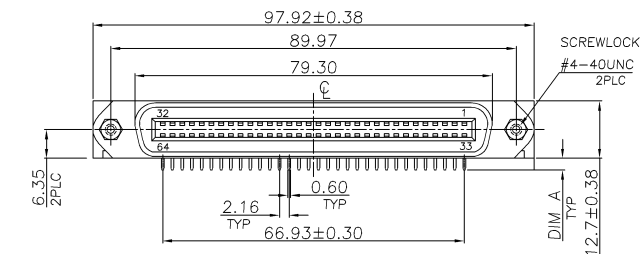
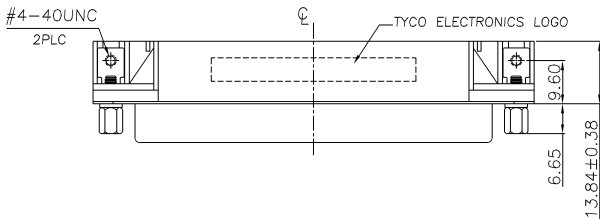

2.0 mm	3.18	1775115-2
1.6 mm	2.60	1775115-1
PCB THICKNESS	DIM A	PART NUMBER

THIS DRAWING IS A CONTROLLED DOCUMENT.

DIMENSIONS:	TOLERANCES UNLESS OTHERWISE SPECIFIED:	DWN	04SEP2007	Tyco Electronics Corporation Taipei, Taiwan				
MM	0 PLC ± -	CHK	J. LEE					
	1 PLC ± 0.3	APVD	S. HOU					
	2 PLC ± 0.2	NAME	W. J. KE					
	3 PLC ± -	PRODUCT SPEC	-	RECEPTACLE ASSEMBLY, 64 POSN, RIGHT ANGLE, CENTRONICS				
	4 PLC ± -	APPLICATION SPEC	-	SIZE	CAGE CODE	DRAWING NO	RESTRICTED TO	
	ANGLES ± 3°	WEIGHT	-	A3	00779	C-1775115	-	
MATERIAL	FINISH	CUSTOMER DRAWING	SCALE	-	SHEET	1 of 2	REV	A

4

3

2

1

THIS DRAWING IS UNPUBLISHED. RELEASED FOR PUBLICATION  
 © COPYRIGHT - BY TYCO ELECTRONICS CORPORATION. ALL RIGHTS RESERVED.

LOC	DIST	REVISIONS			
P	LTR	DESCRIPTION	DATE	DWN	APVD
DW	-	SEE SHEET 1.			

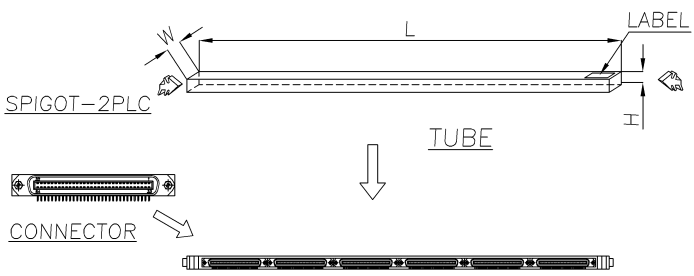

- NOTES:
- MATERIAL:  
 TUBE: PVC  
 INSIDE CARTON: CORRUGATED FIBER  
 SHIPPING BOX: CORRUGATED FIBER
  - DIMENSION:  
 TUBE: 635mm(L)x25.5mm(W)x20mm(H)  
 INSIDE CARTON: 660mm(L)x150mm(W)x135mm(H)  
 SHIPPING BOX: 670mm(L)x315mm(W)x150mm(H)
  - QUANTITY:  
 6 PCS/TUBE  
 30 TUBES/INSIDE CARTON  
 2 INSIDE CARTONS/SHIPPING BOX(360PCS)
  - SHIPPING BOX WEIGHT:  
 NET WEIGHT: 15.5KGS  
 GROSS WEIGHT: 16.5KGS

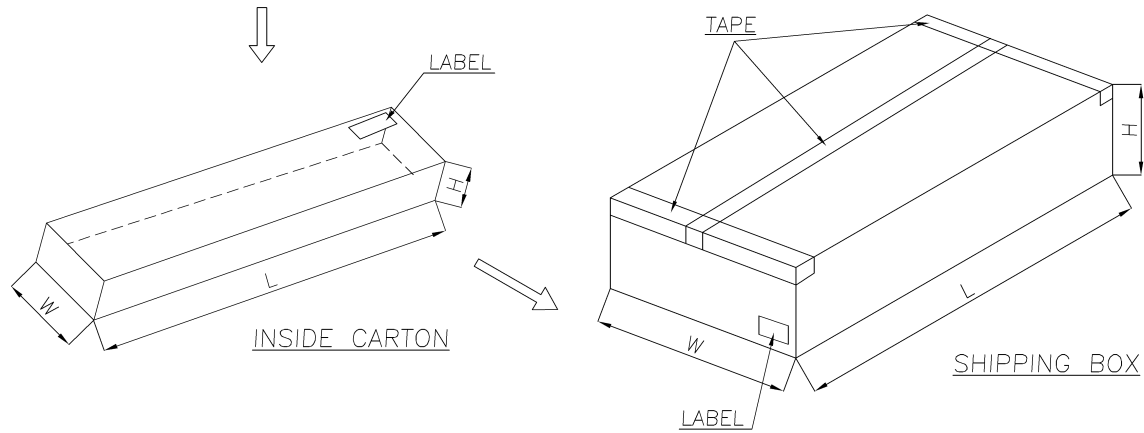

THIS DRAWING IS A CONTROLLED DOCUMENT.		DWN J. LEE 04SEP2007	Tyco Electronics Corporation Taipei, Taiwan															
DIMENSIONS: MM		CHK S. HOU 04SEP2007	NAME RECEPTACLE ASSEMBLY, 64 POSN, RIGHT ANGLE, CENTRONICS															
<table border="1"> <tr> <th>TOLERANCES UNLESS OTHERWISE SPECIFIED:</th> <th></th> </tr> <tr> <td>0 PLC</td> <td>± .05</td> </tr> <tr> <td>1 PLC</td> <td>± .02</td> </tr> <tr> <td>2 PLC</td> <td>± .01</td> </tr> <tr> <td>3 PLC</td> <td>± .005</td> </tr> <tr> <td>4 PLC</td> <td>± .002</td> </tr> <tr> <td>ANGLES</td> <td>± .05</td> </tr> </table>		TOLERANCES UNLESS OTHERWISE SPECIFIED:		0 PLC	± .05	1 PLC	± .02	2 PLC	± .01	3 PLC	± .005	4 PLC	± .002	ANGLES	± .05	APVD W.J. KE 04SEP2007	SIZE A3	
TOLERANCES UNLESS OTHERWISE SPECIFIED:																		
0 PLC	± .05																	
1 PLC	± .02																	
2 PLC	± .01																	
3 PLC	± .005																	
4 PLC	± .002																	
ANGLES	± .05																	
MATERIAL		PRODUCT SPEC	CAGE CODE 00779	DRAWING NO C-1775115														
FINISH		APPLICATION SPEC	RESTRICTED TO															
		WEIGHT	CUSTOMER DRAWING															
		SCALE	SHEET	REV														

AMP 1470-19 REV 31MAR2000