

4

3

2

1

THIS DRAWING IS UNPUBLISHED. RELEASED FOR PUBLICATION
 © COPYRIGHT BY TYCO ELECTRONICS CORPORATION. ALL RIGHTS RESERVED.

LOC	DIST	REVISIONS			
F	LTR	DESCRIPTION	DATE	BY	APP'D
GP	00	A	REVISED PER ECO-07-004221	30MAR07	JDP/EDB

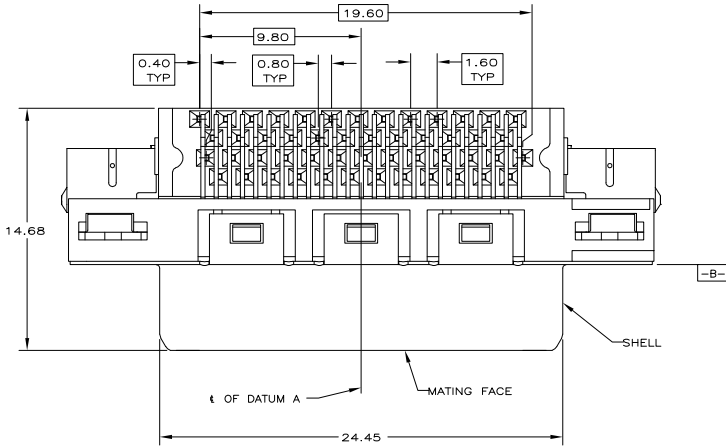

- ⚠ HOUSING & PIN SPACER: THERMOPLASTIC, BLACK, UL 94V-0 RATED.
SHELL: CARBON STEEL.
CONTACTS: PHOSPHOR BRONZE.
BRACKETS: STEEL.
- ⚠ SHELL: 5.08 μm MIN NICKEL OVER 2.54 μm MIN COPPER.
CONTACTS: 0.76 μm MIN GOLD ON MATING END, 3.75 μm MIN TIN ON SOLDER TAILS, BOTH OVER 1.27 μm MIN NICKEL ON ENTIRE CONTACT.
BRACKETS: TIN PLATED.
- ⚠ CONTACTS DESIGNED FOR USE ON 1.60±0.15 THICK PC BOARD WITH PLATED THRU MOUNTING HOLES.
- ⚠ RECEPTACLE ASSEMBLY DESIGNED FOR USE WITH 1.12±0.08 THICK PANEL.
- ⚠ DATUMS AND DIMENSIONS ESTABLISHED BY CUSTOMER.
- ⚠ POSITION TOLERANCE APPLIES AT CONTACT TIP ONLY.

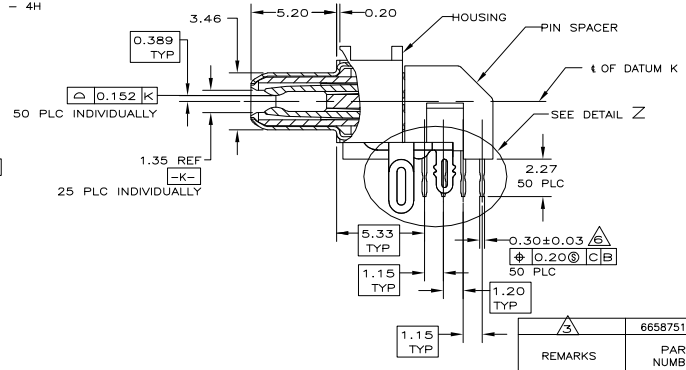
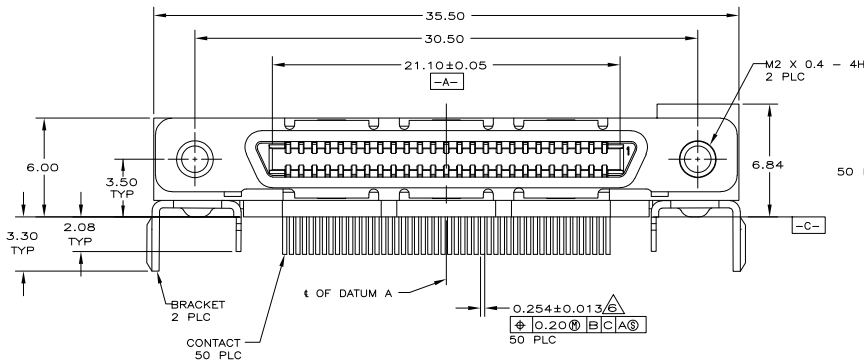

THIS DRAWING IS A CONTROLLED DOCUMENT.		DATE	BY	APP'D	NAME	REMARKS	PART NUMBER
1	VARELA - DOCKES	08-01-05	S. SHUEY	M. WALMSLEY	TYCO Electronics	RECEPTACLE ASSEMBLY, 50 POSITION, SHIELDED, RIGHT ANGLE, CHAMP 0.8mm	6658751-1
2	SHUEY	08-01-05					
3	WALMSLEY	08-01-05					

DIMENSIONS: mm 0 PLC ± - 1 PLC ± - 2 PLC ± 0.13 3 PLC ± - 4 PLC ± - ANGLES ± 1° MATERIAL ⚠ FINISH ⚠	APPLICATION SPEC: - WEIGHT: - CUSTOMER DRAWING	SIZE: A2 CASE CODE (DRAWING NO): 00779 SCALE: 6:1	RESTRICTED TO: - SHEET: 1 of 2 REV: A
---	--	---	---

AMP 1471-9 REV 31MM2000

6658751

A

4

3

2

1

THIS DRAWING IS UNPUBLISHED. RELEASED FOR PUBLICATION
 BY TYCO ELECTRONICS CORPORATION. ALL RIGHTS RESERVED.

LOC	DIST	REVISIONS		
GP	00	F	LTR	DATE
			SEE SHEET 1	

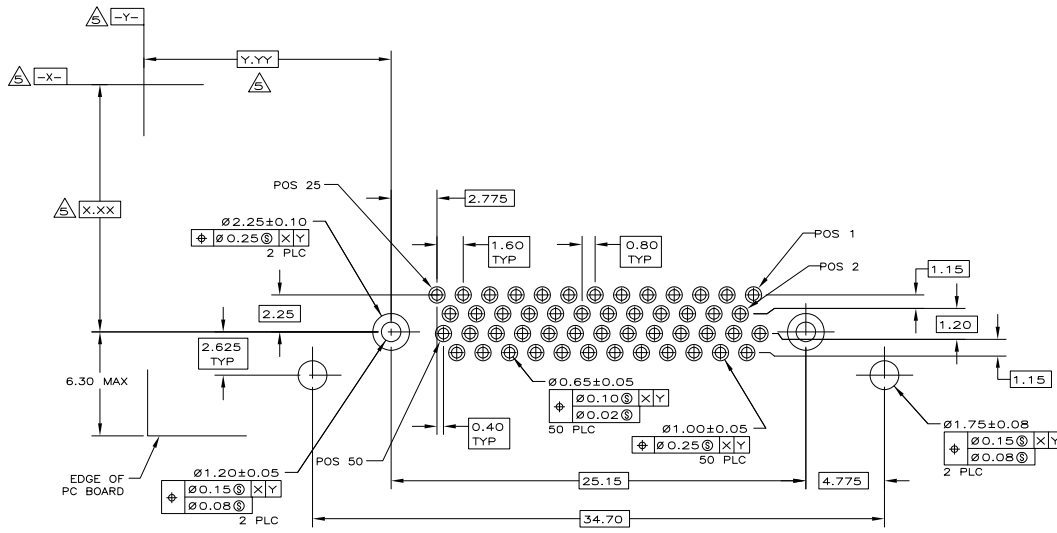

PC BOARD MOUNTING DIMENSIONS Δ

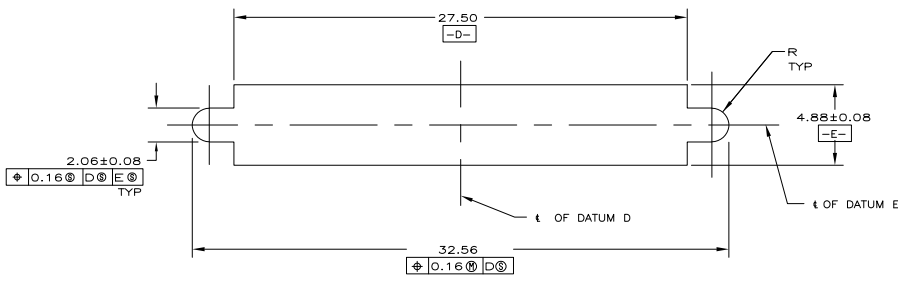

PANEL CUT-OUT DIMENSIONS Δ

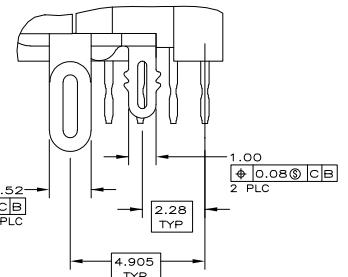

DETAIL Z
SCALE 10:1

THIS DRAWING IS A CONTROLLED DOCUMENT.		DWG	L. VARELA	08-01-05	Tyco Electronics Corporation Harrisburg, Pa 17105-3608
		CHK	S. SHUEY	08-01-05	
		APP'D	M. WALKSELY	08-01-05	RECEPTACLE ASSEMBLY, 50 POSITION, SHIELDED, RIGHT ANGLE, CHAMP 0.8mm
		PRODUCT SPEC			
		APPLICATION SPEC			SIZE
		WEIGHT			A200779
		MATERIAL			C-6658751
		FINISH			RESTRICTED TO
					CUSTOMER DRAWING
					SCALE 6:1
					SHEET 2 OF 2
					REV A

6658751

B

A