

4

3

2

1

THIS DRAWING IS UNPUBLISHED. RELEASED FOR PUBLICATION  
 © COPYRIGHT BY TYCO ELECTRONICS CORPORATION. ALL RIGHTS RESERVED.

LOC	DIST	REVISIONS					
GP	00	F	LR	DESCRIPTION	DATE	BY	APP
		P		REVISED PER ECO-08-007327	17APROB	BM	WM

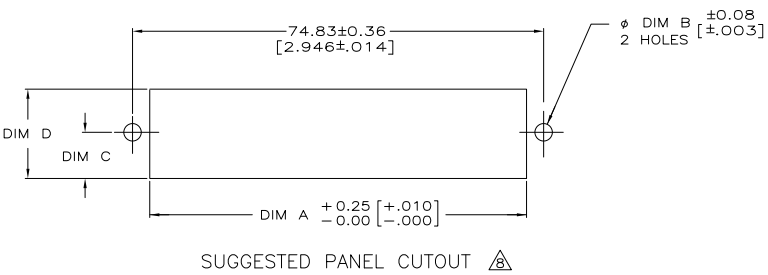
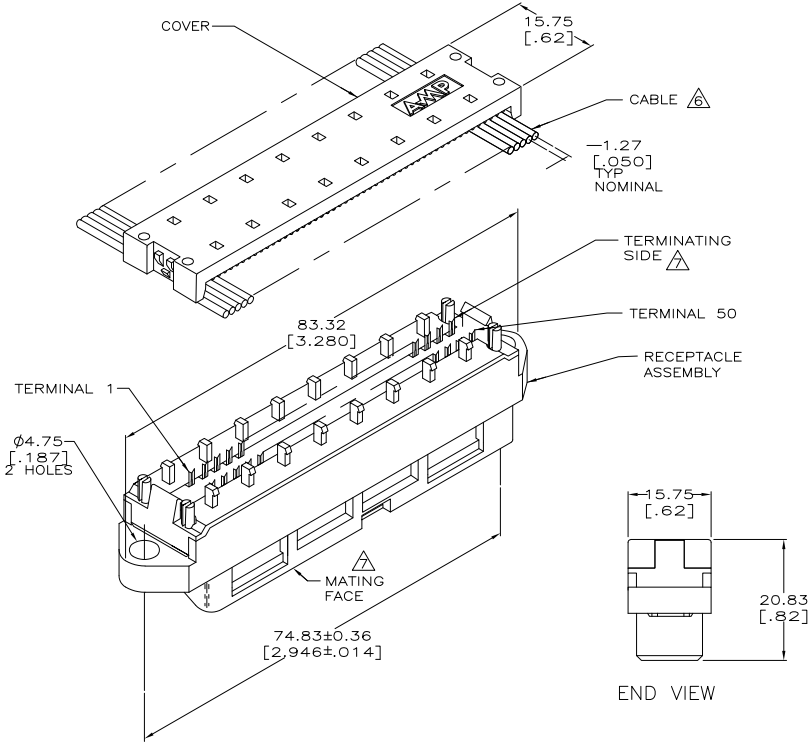

1. THE CONTACT SURFACES OF THE TERMINALS ARE COATED WITH LUBRICANT.
- △ MATERIAL:  
HOUSING & COVER - THERMOPLASTIC (BLACK).  
TERMINALS - PHOS BRONZE PLATED WITH EITHER 0.76µm [.000030] MINIMUM GOLD PLATE OR GOLD FLASH OVER PALLADIUM NICKEL PLATE, 0.76µm [.000030] MIN TOTAL ON MATING SURFACE. GOLD FLASH PLATED ON TERMINATING SIDE. 1.27µm [.000050] MINIMUM NICKEL UNDERPLATE OVER ENTIRE TERMINAL.
- △ BULK PACKAGED 500 PER CONTAINER.
4. WIRE RANGE: 26 AWG SOLID THRU 30 AWG AND 28 AWG STRANDED RIBBON CABLE.
5. ALL DIMENSIONS SHOWN ARE FOR REFERENCE ONLY UNLESS OTHERWISE SPECIFIED.
- △ FLAT CABLE SHALL BE FURNISHED BY CUSTOMER.
- △ MATING FACE CONSISTS OF TWO ROWS OF TERMINALS ON 2.16 [.085] CENTERS. TERMINATING SIDE CONSISTS OF TERMINALS ON 2.54 [.100] CENTERS FOR AN EFFECTIVE 1.27 [.050] TERMINATION.
- △ PANEL THICKNESS RANGE:  
FRONT PANEL MOUNTING - 3.18 [.125] MAXIMUM.  
REAR PANEL MOUNTING - 1.58 [.062] MAXIMUM.
- △ ALL DIMENSIONS SHOWN ARE MAXIMUM UNLESS OTHERWISE SPECIFIED.

DIM D	DIM C	DIM B	DIM A	DESCRIPTION
15.75 [.620]	7.87 [.310]	3.78 [.149]	68.58 [2.700]	REAR PANEL MOUNTING
16.26 [.640]	8.13 [.320]	3.20 [.126]	68.58 [2.700]	FRONT PANEL MOUNTING

100 PER TRAY	ASSEMBLED	554090-1
PACKAGED	COVER	PART NO

THIS DRAWING IS A CONTROLLED DOCUMENT.		DRM K. TILLMAN/JTA 12-17-93	Tyco Electronics Corporation Harrisburg, PA 17105-3608	
DIMENSIONS: mm [INCHES]		CHK C. WHITT 9-2-94	Tyco Electronics	
TOLERANCES UNLESS OTHERWISE SPECIFIED:		APPC J. TRAMMEL 9-9-94	NAME	
Ø PLG ± .00	1 PLG ± .00	PRODUCT SPEC 108-6076	RECEPTACLE ASSEMBLY, 50 POSITION, PANEL MOUNTING, LOW PROFILE, CHAMP LATCH	
2 PLG ± .00	3 PLG ± .00	APPLICATION SPEC 114-6030	SIZE A2	ONE CODE (DRAWING NO) 00779
4 PLG ± .00	ANGLES ± .00	FINISH	RESTRICTED TO	
MATERIAL		HEIGHT	C=554090	
FINISH		CUSTOMER DRAWING	SCALE 2:1	SHEET 1 of 1

AMP 1471-9 REV 31MMR2000

554090

A