

4

3

2

1

THIS DRAWING IS UNPUBLISHED. RELEASED FOR PUBLICATION
 BY AMP INCORPORATED. ALL RIGHTS RESERVED.

LOC	QIBT	REVISIONS			
F	LWR	DESCRIPTION	DATE	QUN	APPD
F <td>8</td> <td>REDRAWN W/O CHANGE PER EC 0320-109-96</td> <td>03 DEC 97</td> <td>-</td> <td>-</td>	8	REDRAWN W/O CHANGE PER EC 0320-109-96	03 DEC 97	-	-

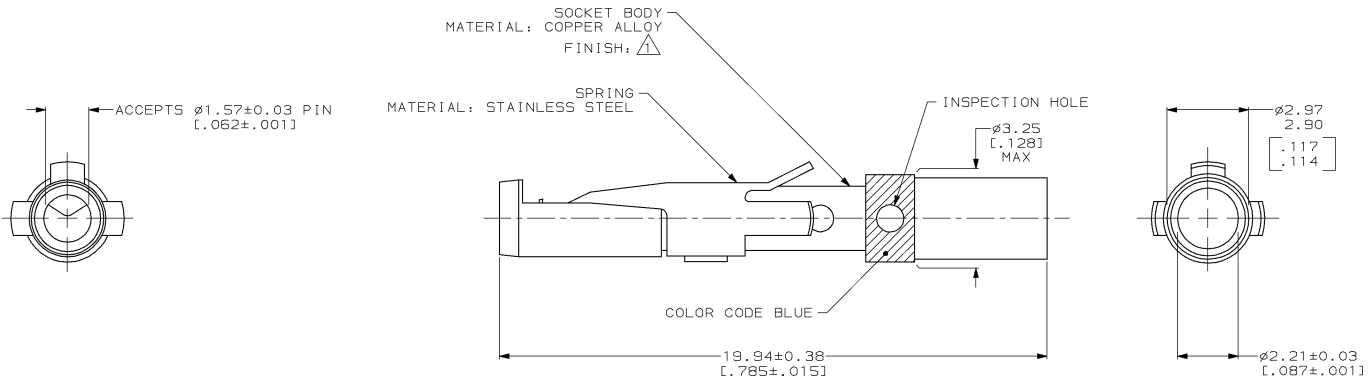

Δ 0.76 μm [.000030] MIN GOLD OVER 1.27 μm [.000050] MIN NICKEL.

202726-1

PART NUMBER

THIS DRAWING IS A CONTROLLED DOCUMENT.		DN S. CARBO	03 DEC 97	AMP AMP Incorporated Harrisburg, PA 17105-3608
DIMENSIONS mm (INCHES)		CHK R. STONE	10 DEC 97	
TOLERANCES UNLESS SPECIFIED		APPR S. STEINHAUER	06 JAN 98	NAME CONTACT ASSEMBLY, SOCKET, #16, WIRE SIZE-(2) #18, TYPE II
0 PLG ±.01 3 PLG ±.01 3 PLG ±.01 4 PLG ±.01 ANGLES ±.01		PRODUCT SPEC	APPLICATION SPEC	
MATERIAL SEE CALLOUTS	FINISH SEE CALLOUTS	WEIGHT	—	SIZE CASE CODE DRAWING NO A200779
CUSTOMER DRAWING		SCALE	10:1	SHEET 1 OF 1 REV F

202726

B

A