

THIS DRAWING IS UNPUBLISHED. RELEASED FOR PUBLICATION .19
 © COPYRIGHT 19 BY AMP INCORPORATED. ALL INTERNATIONAL RIGHTS RESERVED.

LOC		DIST		ZONE		LTR		REVISIONS			
CH	11	P	F					D	ECN 95033001		
										DATE	APPRO
										30MAR95	CMS

1. RETROFIT CONTACT FOR METRIMATE AND AMPLIMITE POWER CONTACT.
2. WIRE BARREL WILL ACCEPT #8 AWG WIRE.
3. MATES WITH PN 193457-1.

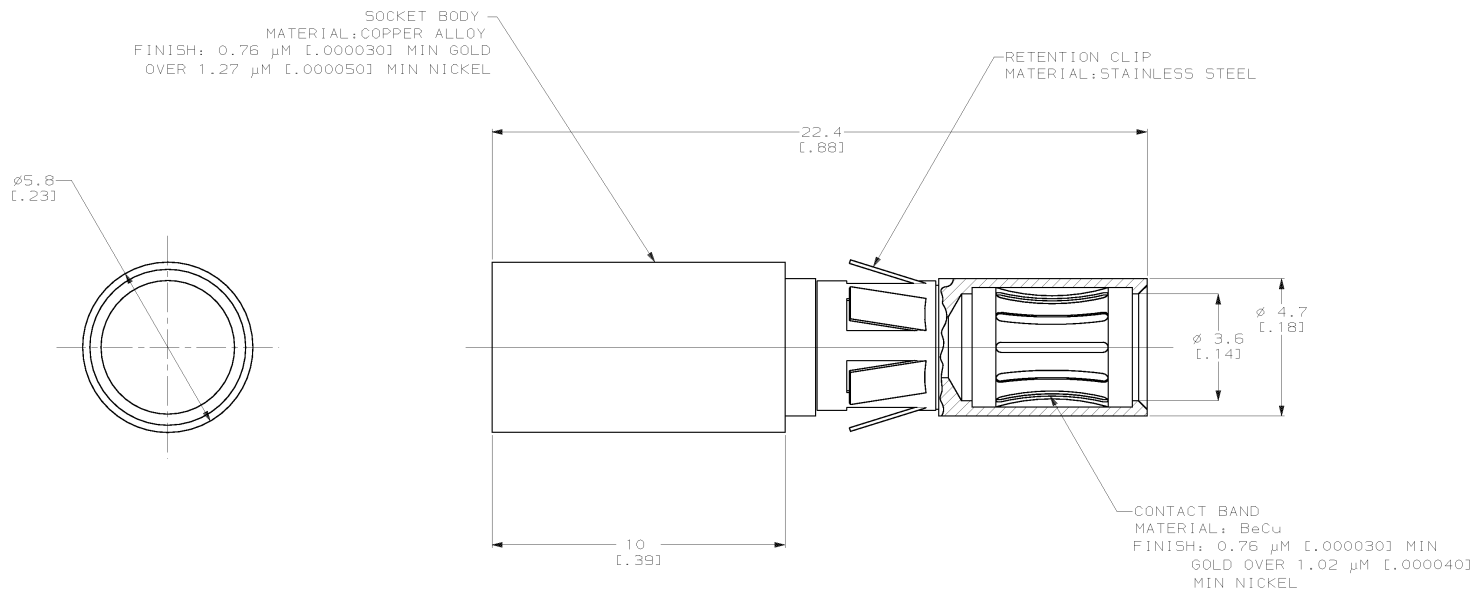

WAS 92-9991-003

THIS DRAWING IS A CONTROLLED DOCUMENT FOR AMP INCORPORATED. IT IS SUBJECT TO CHANGE AND THE CONTROLLING ENGINEERING ORGANIZATION SHOULD BE CONTACTED FOR THE LATEST REVISION.

		193458-1	
		PART NO	
DO NOT SCALE PRINT. UNLESS SPECIFIED DIMENSIONS IN mm [INCHES] TOLERANCES ON: 2 PLC DEC ± 0.5 [0.02] 3 PLC DEC ± 0.25 [0.010] ANGLES ± - 0.25 [0.010]		DR D. WILSON 05-27-92	AMP Incorporated Harrisburg, PA 17105-3608
MATERIAL		CHK S. STEGRIST 05-27-92	
FINISH		APPD A. GRIFFIN 05-27-92	NAME
		APPD P. GLASER 05-27-92	SOCKET, POWER, #8 AWG
		PRODUCT SPEC	
		APPLICATION SPEC	SIZE
			CAGE CODE
			DRAWING NO
			00779
			C=193458
		WEIGHT	SCALE
			10:1
			SHEET
			1 OF 1

CUSTOMER DRAWING