

LOC	DIST	REVISIONS				
P	LTR	DESCRIPTION	DATE	DWN	APVD	
E	B	F	EBD0-0463-04	08DEC04	RS MG	
		F1	REVISED PER ECO-09-020689	24AUG09	KK AEG	

NOTES:

- ① FOR STRIP VERSION SEE DWG. 164153.
- ② UNDERCOATING: 1,3µm Ni.
SELECTIVE : 0,8µm Au.
ZONE I : BRIGHT TIN PLATED.
- ③ UNDERCOATING: 1,3µm Ni.
SELECTIVE : 0,8µm Au.
REMAINDER : GOLDFLASH.
- ④ OBSOLETE PARTS: OBSOLETE CIS STREAMLINING PER D.RENAUD/D.SINISI

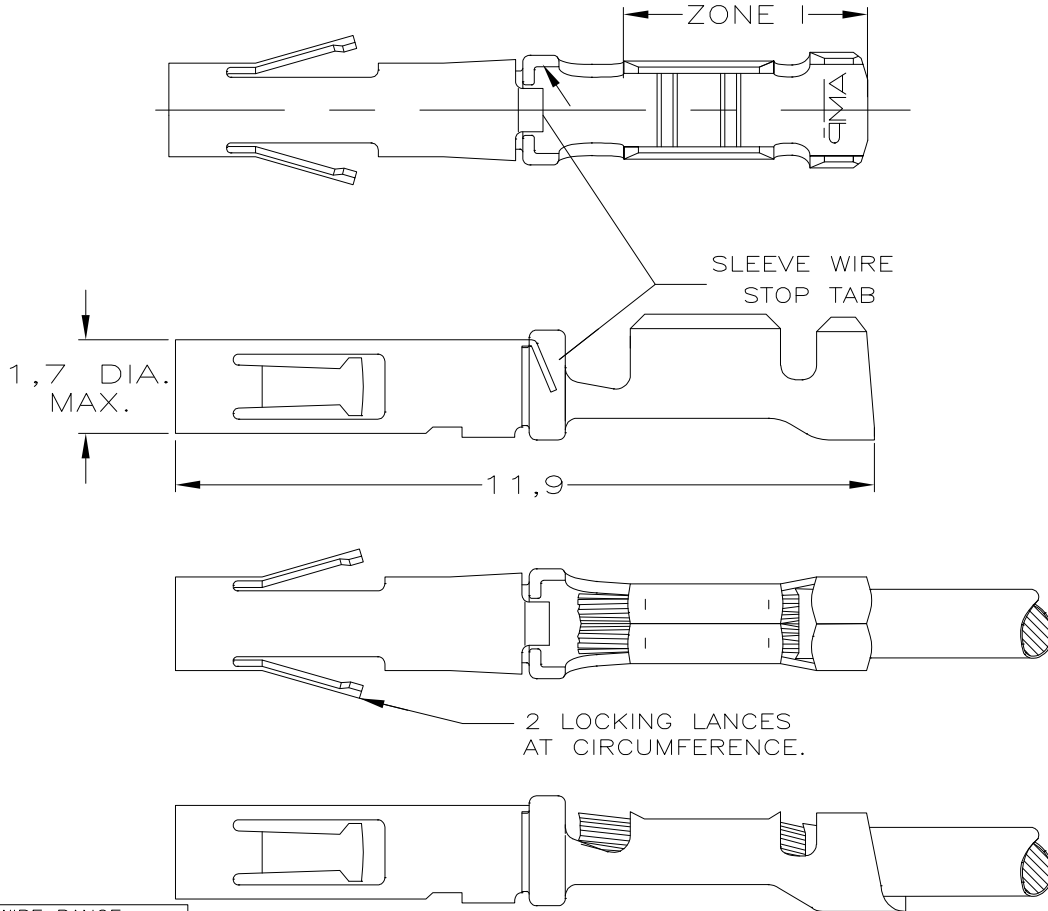

WIRE RANGE :
24-20 AWG 0,20-0,56 mm²
INSULATION RANGE :
1,57 DIA. MAX.

STAINLESS STEEL	SEE NOTE ②	BRASS	164169-4
	PRETINNED		164169-3
	POST TINPLATED		④ 164169-2
	SEE NOTE ③		164169-1
MATERIAL OF SLEEVE	PLATING OF BODY	MATERIAL OF BODY	PARTNUMBER

THIS DRAWING IS UNPUBLISHED. JAN , 1993. ALL RIGHTS RESERVED. BY TYCO ELECTRONICS CORPORATION.

DIMENSIONS: mm		DWN J.v.LIEMPT 6 JAN 1993	MATERIAL -	FINISH -
TOLERANCES UNLESS OTHERWISE SPECIFIED:		CHK C.v.TILBURG 08-02-93	Tyco Electronics Corporation Harrisburg, PA 17105-3608	
0 PLC ± - 1 PLC ± - 2 PLC ± - 3 PLC ± - 4 PLC ± - ANGLES ± -		APVD L.v.SOEST 08-02-93		
PRODUCT SPEC -		NAME HDR SOCKET CONTACT TYPE XI (CRIMP SNAP-IN) L.P.		
APPLICATION SPEC -		SIZE A4	CAGE CODE 00779	DRAWING NO C-164169
WEIGHT -		RESTRICTED TO -		
		CUSTOMER DRAWING		
		SCALE -	SHEET 1 OF 1	REV F1