

PART NO.	ENG. NO.
02-06-1101	1561-IP901
02-06-1103	1561-IP901L
02-06-5101	1561-IP561
02-06-5102	1561-IP561L
02-06-5108	1561-IP228
02-06-5109	1561-IP228L
02-06-5100	1561-IP550
02-06-5103	1561-IP550L
02-06-5105	1561-IP591
02-06-5104	1561-IP591L
02-06-1118	1561-IP901
NOT TOOLED	1561-IP901L

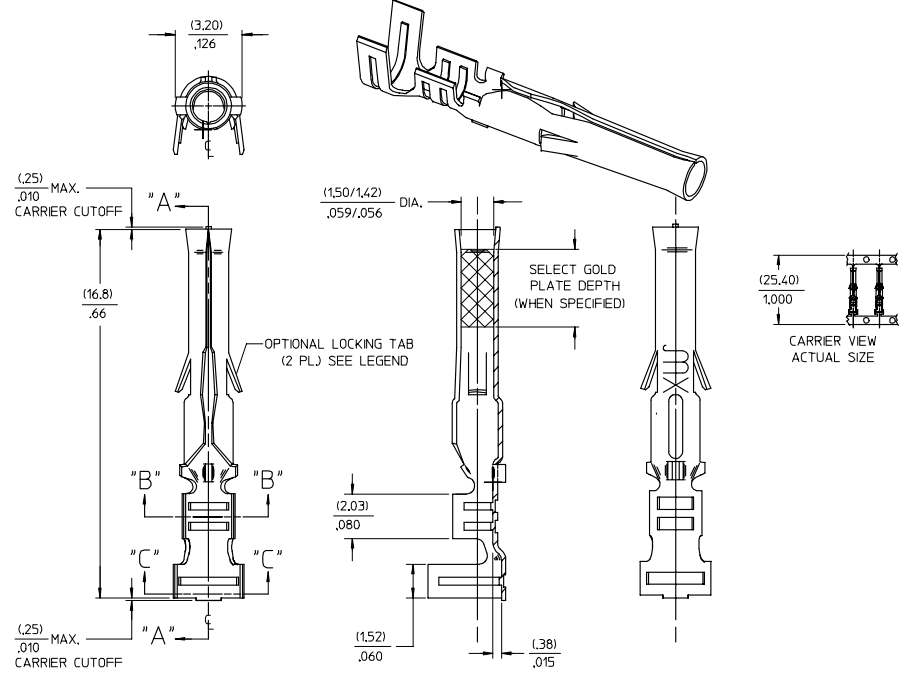
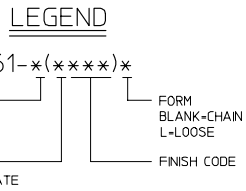
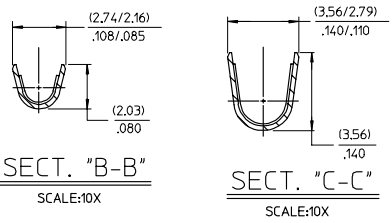

- NOTES:
1. MATERIAL: BRASS
  2. FINISH:
    - 901 HOT TIN DIP (.00051)/.000020 MIN.
    - 228 SELECT GOLD PLATE (.00075)/.000030 MIN. IN CONTACT AREA. SELECT TIN, (.00250)/.000100 MIN. IN CRIMP AREA OVER (.00125)/.000050 MIN. NICKEL OVERALL.
    - 561 SELECT GOLD PLATE (.00076)/.000030 MIN. IN CONTACT AREA. OVER (.00127)/.000050 MIN. NICKEL OVERALL.
    - 591 SELECT GOLD PLATE (.00175)/.000050 MIN. IN CONTACT AREA. OVER (.00127)/.000050 MIN. NICKEL OVERALL WITH (.000025)/.000010 MAX. GOLD FLASH OVERALL.
    - 550 SELECT GOLD PLATE (.00038)/.000015 MIN. IN CONTACT AREA. OVER (.00076)/.000030 MIN. NICKEL OVERALL WITH (.000025)/.000010 MAX. GOLD FLASH OVERALL.
  - \* THE PRIMARY SHIPPING CARTON WILL BE LABELED, 'COMPLIANT TO ROHS DIRECTIVE 2004/95/EC AND ANNEX II OF DIRECTIVE 2000/53/EC', AND CARTONS WITHOUT THIS LABEL MAY CONTAIN PRODUCT WITH TIN-LEAD."
  3. PRODUCT SPECIFICATION: PS-02-06.
  4. PACKAGING INFORMATION: NOT AVAILABLE
  5. TERMINAL FOR USE WITH (1.57)/.062 DIA. SERIES HOUSINGS AND WILL ACCEPT 18 THRU 24 AWG WIRE WITH (1.52/3.05)/.060/.120 INSULATION DIA.

SEE REVISION BLOCK SEC NO. UCP2004-2257 DRAWN BY: DRW:RHOLTS 2005/03/30 CHKD:FSMTH 2005/03/30 APPR:FSMTH 2005/04/11	QUALITY SYMBOLS	GENERAL TOLERANCES (UNLESS SPECIFIED)	SCALE 6:1	DESIGN UNITS INCH	THIRD ANGLE PROJECTION	REVISE ON CAD ONLY	
	4 PLACES ± --- ± --- 3 PLACES ± --- ± .005 2 PLACES ± 0.13 ± .010 1 PLACE ± 0.25 ± --- ANGULAR ±1/2°	DIMENSION STYLE IN/MM	DRAWN BY DATE 1991/02/19	TITLE CRIMP TERMINAL, FEMALE .062 DIA. FOR 18-24 AWG WIRE			
	DRAFT WHERE APPLICABLE MUST REMAIN WITHIN DIMENSIONS	CHECKED BY DATE	MATERIAL NO. SEE CHART				
		APPROVED BY DATE 1991/02/19	DOCUMENT NO. SD-1561-* SHEET NO. 1 OF 1				

AP	REVISED/REDRAWN UCP2004-2257 RHOLTS 03/14/04
AO	REINSTATE 02045105 UCP2003-3877 ELHAG 03/02/24
AN	OBsolete P/N UCR2002-0270 COMERC 01/9/25
AM1	ADDED ISO VIEW UCR998-0248 WANG 98-05-21
AM	REV. AND REDRAWN PER ECR 10392 CEP 8-20-87 RW

tb\_frame\_C\_P\_ME\_T Rev. C 2002/05/05