

PART NO.	ENG. NO.	
02-06-1131	1855-(P901)	
02-06-1132	1855-(P901L)	
02-06-5137	1855-(P591)	OBSOLETE
02-06-5136	1855-(P591L)	OBSOLETE
02-06-5138	1855-(P561)	
02-06-5139	1855-(P561L)	
02-06-5130	1855-(P550)	
02-06-5135	1855-(P550L)	
02-06-5147	1855-(P228)	
02-06-5148	1855-(P228L)	
02-06-1141	1855-1(P901)	
NOT TOOLED	1855-1(P901L)	
02-06-1143	1855-(P9011)	

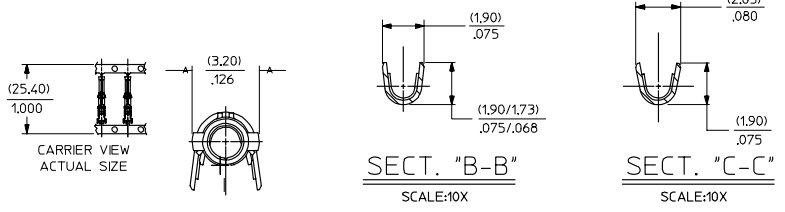

**LEGEND**

1855-\*(\*\*\*)\*

BLANK-WITH LOCKING TABS  
1-WITHOUT LOCKING TABS

P=PREPLATE  
BLANK-POSTPLATE

FORM  
BLANK=CHAIN  
1=CHAIN WITH INTERLEAF  
PAPER ON REEL,  
L=LOOSE

FINISH CODE

- NOTES:**
- MATERIAL: BRASS
  - FINISHES:
    - 901 HOT TIN DIP (.00051)/.000020 MIN.
    - \* 228 SELECT GOLD PLATE (.00075)/.000030 MIN. IN CONTACT AREA, SELECT TIN (.00250)/.000100 MIN. IN CRIMP AREA OVER (.00125)/.000050 MIN. NICKEL OVERALL, WITH (.000010/(0.00025) MAX. SELECT GOLD FLASH IN AREA INDICATED.
    - 561 SELECT GOLD PLATE (.00076)/.000030 MIN. IN CONTACT AREA, (.00127)/.000050 MIN. NICKEL OVERALL.
    - 591 SELECT GOLD PLATE (.00127)/.000050 MIN. IN CONTACT AREA, OVER (.00127)/.000050 MIN. NICKEL OVERALL WITH (.00025)/.000010 MAX. GOLD FLASH OVERALL.
    - 550 SELECT GOLD PLATE (.00038)/.000015 MIN. IN CONTACT AREA, OVER (.00076)/.000030 MIN. NICKEL OVERALL WITH (.00025)/.000010 MAX. GOLD FLASH OVERALL.
  - THE PRIMARY SHIPPING CARTON WILL BE LABELED, \*COMPLIANT TO RoHS DIRECTIVE 2002/95/EC AND ELV ANNEX II OF DIRECTIVE 2000/53/EC THIS LABEL MAY CONTAIN PRODUCT WITH TIN-LEAD.
  - PRODUCT SPECIFICATION: PS-02-0-6
  - PACKAGE INFORMATION: NOT AVAILABLE
  - TERMINAL FOR USE WITH (1.57)/.062 DIA. SERIES HOUSINGS AND WILL ACCEPT 24 THRU 30 AWG WIRE WITH (1.02/2.29)/.040/.090 INSULATION DIAMETER.

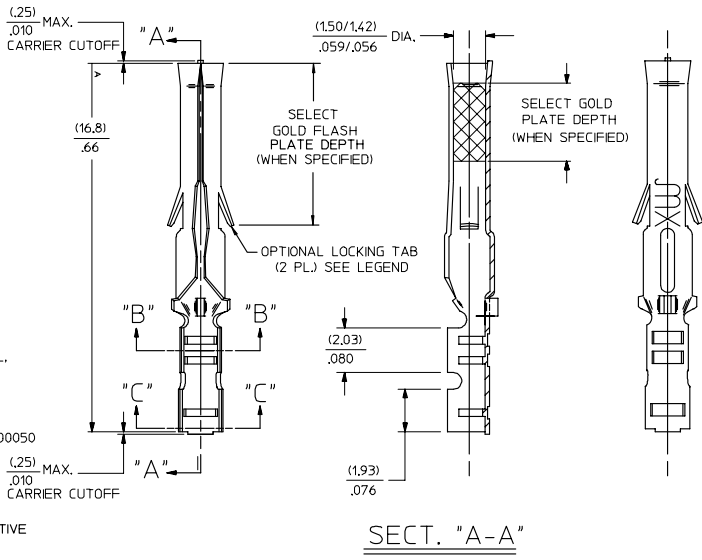

AP	REVISE S/N/PB PLATE REPAIR TO 45° UCP2004-209 5/07/04 RW/STL
AN	OBSOLETE P/N UCP2002-0276 COHER 01/9/28
AM1	OBSOLETE #0525 & #535L ECR 1/4 0368 GC/9/15/95 RW
AM	REV. AND REDRAWN PER ECR 0372 GEP 6-17-87 RW

REV. MATL. SPEC/STAT TO HEAD EC NO. UCP2004-2097 DRAWN: ROLTS 2004/05/14 CHKD: 2004/05/14 APPR: F SMITH 2004/05/18	QUALITY SYMBOLS	GENERAL TOLERANCES (UNLESS SPECIFIED)	SCALE 8:1	DESIGN UNITS INCH	THIRD ANGLE PROJECTION	REVISE ON CAD ONLY
	0	4 PLACES ± --- ± --- 3 PLACES ± --- ± 1 2 PLACES ± 0.25 ± 0.14 1 PLACE ± 0.35 ± --- ANGULAR ± 1/2°	mm INCH	DIMENSION STYLE IN/MM	TITLE	
AP	DESCRIPTION	DRAFT WHERE APPLICABLE MUST REMAIN WITHIN DIMENSIONS	DRAWN BY GEP	DATE 1987/09/17	CRIMP TERMINAL, FEMALE (1.57)/.062 DIA., BRASS FOR 24 THRU 30 GA. WIRE	
			CHECKED BY RW	DATE 1987/09/17	MOLEX INCORPORATED	
			APPROVED BY RAS	DATE 1987/09/17	MATERIAL NO. SEE CHART	DOCUMENT NO. SD-1855-*
						SHEET NO. 1 OF 1