

DRAWING MADE IN THIRD ANGLE PROJECTION
 THIS DRAWING IS UNPUBLISHED. RELEASED FOR PUBLICATION .19
 © COPYRIGHT 19 BY AMP INCORPORATED. ALL INTERNATIONAL RIGHTS RESERVED.

MOD		LOC	DIST	REVISIONS			
P	F	ZONE	LTR	DESCRIPTION	DATE	APPD	
			AE	REDRAWN, ADDED 1--4 PER NPR 3506	5-9-91	RW	
			AF	ADDED 1--5 PER NPR 4680	04/02/93	RSK	
			AF1	REVISED PER ECO-09-020935	09SEP99	AEG	

WHEN ORDERING CONTACT ASSEMBLY ON TAPE, ORDER BY THE TAPE NUMBER PLUS THE PACKAGING CODE AS FOLLOWS:
 1. FOR USE WITH AMP TAPETRONIC, PNEUMATIC TOOL-
 A. 1000 PARTS TO A BOX ADD PACKAGING CODE: 1MBOX
 2. FOR USE WITH 4/8 INDENT STRIPPER CRIMPER-
 A. 1000 PARTS TO A REEL ADD PACKAGING CODE: 1MREEL
 B. 5000 PARTS TO A REEL ADD PACKAGING CODE: 5MREEL
 3. OBSOLETE PARTS: OBSOLETE CIS STREAMLINING PER D.RENAUD/D.SINISI

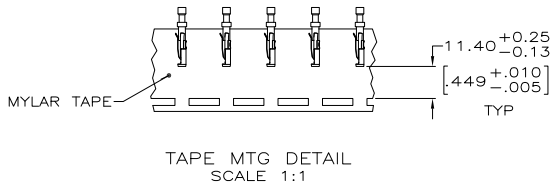
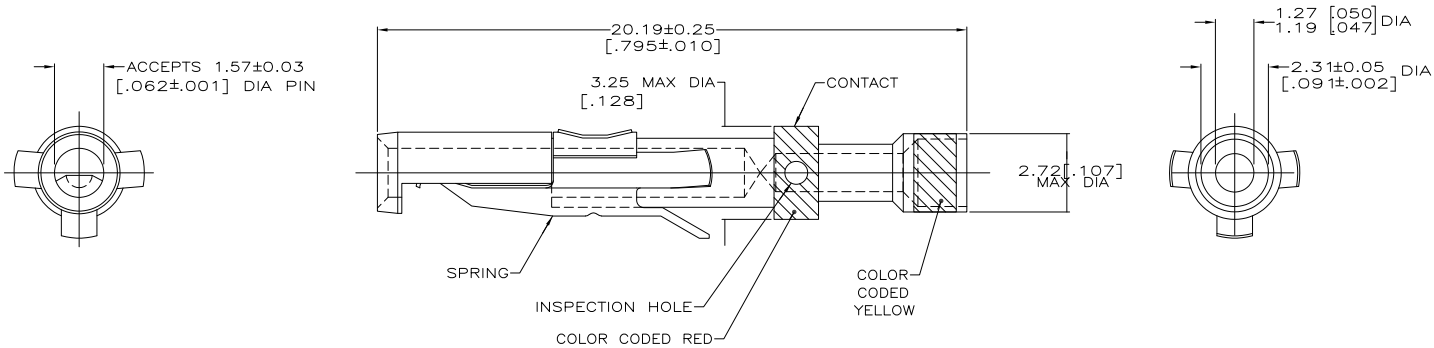

3 OBSOLETE	SMALL PACK	1-201328-5
	KIT	1-201328-4
	TAPE MTG SEE DETAIL	201328-9
	BULK	201328-1
	PACKAGING	PART NO

DO NOT SCALE PRINT. UNLESS SPECIFIED DIMENSIONS IN mm [INCHES]		DR 5-9-91 W.GLENKER		AMP Incorporated Harrisburg, PA 17105-3608
TOLERANCES ON :		CHK 5-14-91 R.STONE		
2 PL DEC ± -		APPD 5-14-91 R.WALTER		NAME
3 PL DEC ± -		MATERIAL		SOCKET CONTACT ASSEMBLY, TYPE II
ANGLES ± -		CONTACT: BRASS SPRING: STAINLESS STEEL		
FINISH		APPLICATION SPEC	SIZE	CAGE CODE
CONTACT: 0.76 μm [.000030] MIN GOLD OVER 1.27 μm [.000050] MIN NICKEL		-	10:1	00779
WEIGHT		-	SCALE	DRAWING NO
		-		201328
				SHEET 1 OF 1

AMP 1471-6 REV 9-89 Transferred from 01031.130328 (VMM) (MCD) (HARMSS) from Computerized, Inc., Medium Revision 12.2.97

CUSTOMER DRAWING

201328