

THIS DRAWING IS UNPUBLISHED. RELEASED FOR PUBLICATION .19
 © COPYRIGHT 19 BY AMP INCORPORATED. ALL INTERNATIONAL RIGHTS RESERVED.

REVISIONS									
MOD	LOC	DIST	P	F	ZONE	LTR	DESCRIPTION	DATE	APPD
4	BD	39				U	ADDED -8 PER NPR 4680 AND REDRAWN ON CAD	04/06/93	-
						U1	REVISED PER ECO-09-020935	08SEP09	KK/AG

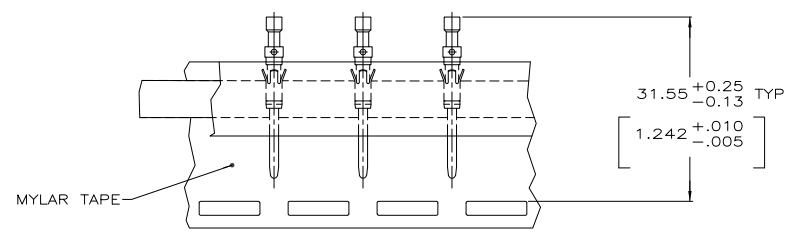
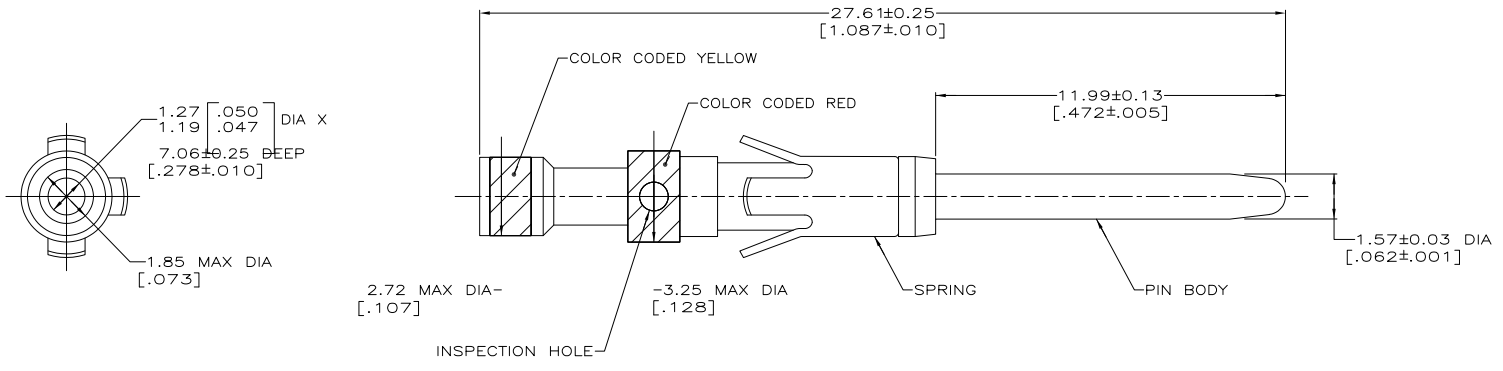

TAPE MTG DETAIL
SCALE 2:1

- ⚠ 0.76µm [.000030] MIN GOLD OVER 1.27µm [.000050] MIN NICKEL.
- ⚠ WHEN ORDERING CONTACT ASSEMBLY ON TAPE, ORDER BY THE TAPE NUMBER PLUS THE PACKAGING CODE AS FOLLOWS:
 1. FOR USE WITH AMP TAPETRONIC, PNEUMATIC TOOL-
 - A. 1000 PARTS TO A BOX ADD PACKAGING CODE: 1MBOX
 2. FOR USE WITH 4/8 INDENT STRIPPER CRIMPER-
 - A. 1000 PARTS TO A REEL ADD PACKAGING CODE: 1MREEL
 - B. 5000 PARTS TO A REEL ADD PACKAGING CODE: 5MREEL
- ⚠ OBSOLETE PARTS: OBSOLETE CIS STREAMLINING PER D.RENAUD/D.SINISI

⚠ OBSOLETE	SMALL PACK	-201578-8-
	TAPE MTG (SEE DETAIL) ⚠	201578-4
	STANDARD	201578-1

PACKAGING TYPE		PART NO	
DO NOT SCALE PRINT. UNLESS SPECIFIED DIMENSIONS IN mm [INCHES]	DR 04/06/93 D.GELTZ	AMP Incorporated Harrisburg, PA 17105-3608 CONTACT ASSEMBLY, PIN, #16, 20-24 AWC, TYPE II	
TOLERANCES ON :	CHK 4-26-93 R.STONE		
2 PLC DEC ± -	APPD 4-29-93 R.S.KLINE		
3 PLC DEC ± -	ANGLES ± -		
MATERIAL	APPD -	NAME	
PIN BODY: COPPER ALLOY	PRODUCT SPEC -	SIZE	CAGE CODE
SPRING: STAINLESS STEEL	APPLICATION SPEC -	SCALE	DRAWING NO
FINISH	PIN BODY: ⚠	10:1	00779
			C-201578
			SHEET 1 OF 1

THIS DRAWING IS A CONTROLLED DOCUMENT FOR AMP INCORPORATED. IT IS SUBJECT TO CHANGE AND THE CONTROLLING ENGINEERING ORGANIZATION SHOULD BE CONTACTED FOR THE LATEST REVISION.