

4

3

2

1

THIS DRAWING IS UNPUBLISHED. RELEASED FOR PUBLICATION
 © COPYRIGHT BY TYCO ELECTRONICS CORPORATION. ALL RIGHTS RESERVED.

WHEN ORDERING CONTACT ON TAPE, ORDER BY THE TAPE NUMBER PLUS THE PACKAGING CODE AS FOLLOWS:

- 2. FOR USE WITH AMP TAPETRONIC, PNEUMATIC TOOL-
 A. 1000 PARTS TO A BOX ADD PACKAGING CODE: 1MBOX
- 3. FOR USE WITH 4/8 INDENT STRIPPER CRIMP-
 A. 1000 PARTS TO A REEL ADD PACKAGING CODE: 1MREEL
 B. 5000 PARTS TO A REEL ADD PACKAGING CODE: 5MREEL

LOC	DIST	REVISIONS					
DF	DO	P	LTR	DESCRIPTION	DATE	BY	APPD
		T		REV PER EDD 07-025060	10-29-07	CT	BW

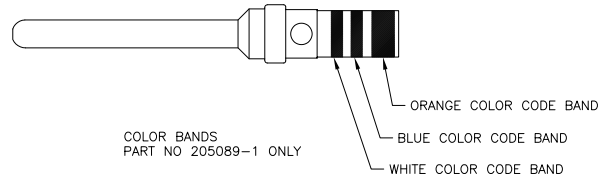
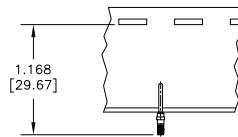
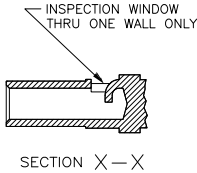
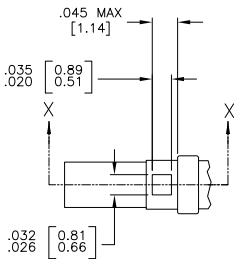
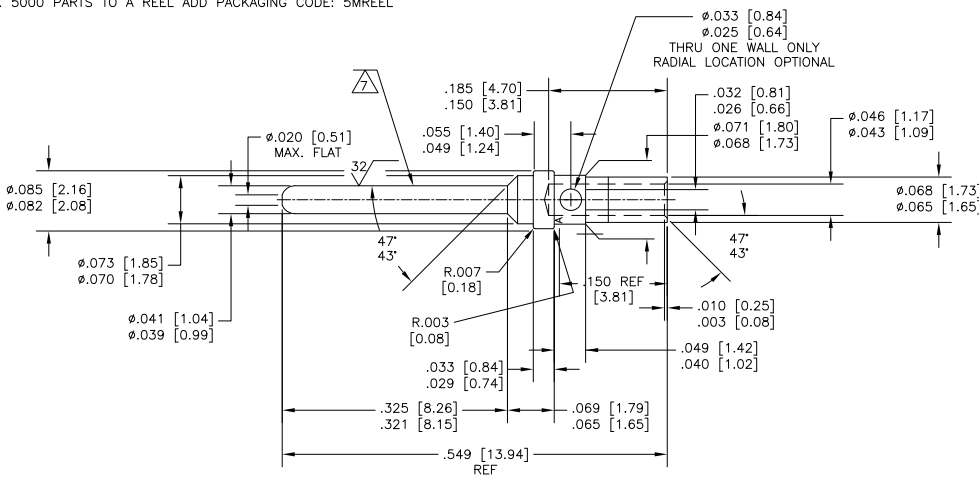

- 1. MATERIAL: COPPER ALLOY PER MIL-C-39029 & MIL-DTL-24308.
- 2. ALL DIMENSIONS APPLY AFTER PLATING.
- 3. THIS DRAWING COMPLIES WITH SPECIFICATION MIL-C-39029/64 & M24308/11-1.
- 4. ALL DIAMETERS CONCENTRIC WITH EACH OTHER WITHIN .004 T.I.R.
- 5. PIN MATES WITH SOCKET 205090 (MIL-C-39029/63).
- 6. ALL SURFACES HAVE 63 OR BETTER FINISH, UNLESS SHOWN.
- 7. POINT OF PLATING MEASUREMENT .188 [4.78] FROM TIP OF PIN.
- 8. PLATING: GOLD PER ASTM-B-488 (TYPEII) OVER NICKEL PER QQ-N-290.
- 9. PLATING: GOLD PER ASTM-B-488 (TYPEII) OVER COPPER PER MIL-C-14550, CLASS 4.
- 10. PLATING: GOLD PER ASTM-B-488 (TYPE II, CLASS 0) OVER NICKEL PER QQ-N-290.

WITHOUT COLOR CODE	1-205089-1
WITHOUT COLOR CODE	1-205089-0
WITHOUT COLOR CODE	205089-4
CONTACT ON TAPE	SAME AS -1
AS SHOWN	205089-1
DESCRIPTION	PLATING PART NO.

THIS DRAWING IS A CONTROLLED DOCUMENT.		BY: J. KAISER	DATE: 25AUG2003	Tyco Electronics Corporation	
DIMENSIONS: INCHES		CHK: D. MILLER	DATE: 10-13-03	Harrisburg, PA 17105-3608	
OTHER DIMENSIONS: MILLIMETERS		APP: D. MILLER	DATE: 10-13-03	PIN SIZE 20 CONTACT, AMPLIMITE	
MATERIAL: COPPER ALLOY		FINISH: 63	APPLICATION SPEC: MIL-C-39029	SIZE: A2	CAGE CODE: 00779
FINISH: 63		WEIGHT: -	PRODUCT SPEC: -	DRAWING NO: C-205089	RESTRICTED TO: -
CUSTOMER DRAWING		SCALE: 10:1		SHEET: 1 of 1	REV: T

AMP 1471-9 REV 31MM2000

30OCT2007 8:22am us016412 H:\docmod\205089_1_c.dwg

205089

B

A