

4

3

2

1

THIS DRAWING IS UNPUBLISHED. RELEASED FOR PUBLICATION  
 © COPYRIGHT BY TYCO ELECTRONICS CORPORATION. ALL RIGHTS RESERVED.

LOC	DIST	REVISIONS			
P	LTR	DESCRIPTION	DATE	DWN	APVD
BD	39	G	0G3B-0317-03	24APR03	TK GS

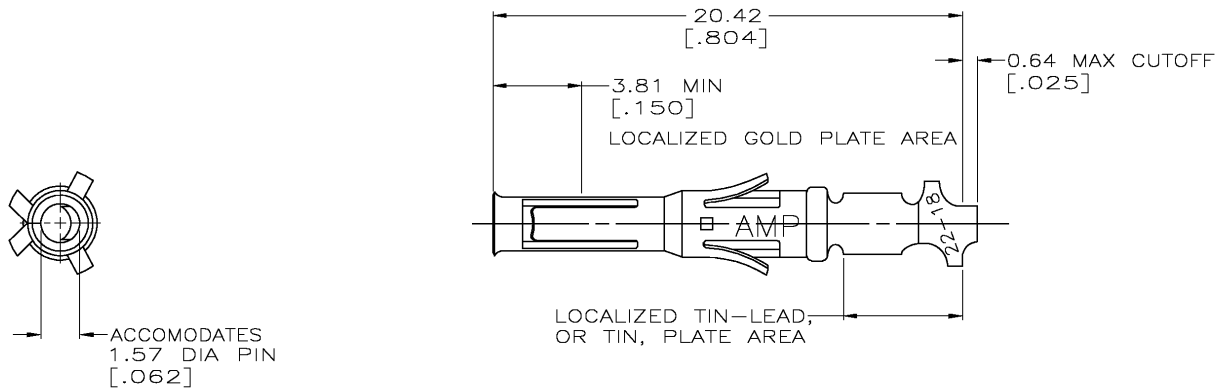

1. WIRE RANGE 18-22 AWG.
2. INSULATION RANGE 1.27-2.79 [.050-.110] DIA.
3. 0.76µm [.000030] MIN GOLD IN LOCALIZED GOLD PLATE AREA, 1.27µm [.000050] MIN TIN-LEAD IN LOCALIZED TIN-LEAD PLATE AREA, BOTH OVER 1.27µm [.000050] MIN NICKEL.
4. TIN PLATED.
5. GOLD PLATING PER MIL-G-45204, TIN PER MIL-T-10727 AND NICKEL PER QQ-N-290.
6. 0.76µm [.000030] MIN GOLD IN LOCALIZED GOLD PLATE AREA, 1.27µm [.000050] MIN TIN IN LOCALIZED TIN PLATE AREA, BOTH OVER 1.27µm [.000050] MIN NICKEL.

66582-7	6	66592-4
66582-4	3	66592-2
66582-2	4	66592-1
STRIP REF	FINISH	PART NO

THIS DRAWING IS A CONTROLLED DOCUMENT.		DWN D.HARDY 06/15/94	Tyco Electronics Corporation Harrisburg, Pa	
DIMENSIONS: INCHES	TOLERANCES UNLESS OTHERWISE SPECIFIED:	CHK R.STONE 06/22/94	NAME G.STEINHAUER 06/27/03	
0 PLC ± -	1 PLC ± -	PRODUCT SPEC	CONTACT, SOCKET, LOOSE PIECE, TYPE VI, MULTIMATE	
2 PLC ± 0.13 [.005]	3 PLC ± -	APPLICATION SPEC	SIZE A3	CAGE CODE 00779
4 PLC ± -	5 ANGLES ± -	WEIGHT	DRAWING NO 66592	RESTRICTED TO
MATERIAL BRS PER MIL-C-50	FINISH 5 SEE TABLE	CUSTOMER DRAWING	SCALE 6:1	SHEET 1 OF 1
			REV G	

AMP 1470-19 REV 31MAR2000

J:\modsvcs\Tina\_EC\_dwg\