

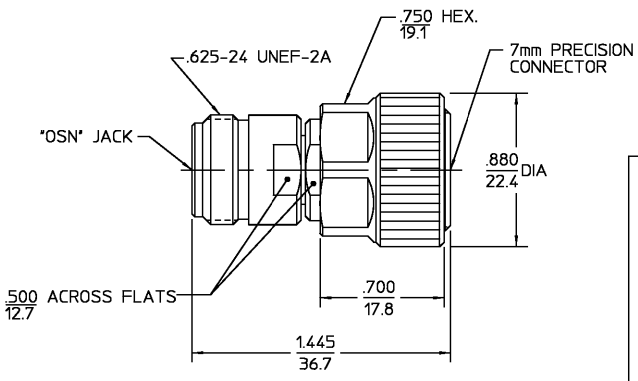

REVISIONS			
REV	DESCRIPTION	DATE	APPROVED
03 ₁	REVISED	12/11/78	<i>[Signature]</i>
B	PER EC 0U20-0116-01-03	16NOV01	<i>[Signature]</i> 16NOV01



COMPONENT	MATERIAL	FINISH
SLIDE ASS'Y COUPLING NUT	STAINLESS STEEL PER ASTM-A484 AND ASTM-A582, TYPE 303	ELECTRO-POLISHED
HOUSING	STAINLESS STEEL PER ASTM-A484 AND ASTM-A582, TYPE 303	GOLD PLATE PER MIL-G-45204
HOUSING	STAINLESS STEEL PER ASTM-A484 AND ASTM-A582, TYPE 303	PASSIVATE PER QQ-P-35
DIELECTRIC	TFE FLUOROCARBON PER ASTM-D-1457	N/A
CONTACT EXT.	BERYLLIUM COPPER PER ASTM-B-196 OR ASTM-B-197, ALLOY C17300, CONDITION H	GOLD PLATE PER MIL-G-45204
GASKET	SILICONE RUBBER PER ZZ-R-765	N/A
RETAINING RING	BERYLLIUM COPPER PER ASTM-B-194, ALLOY C17200, CONDITION H	N/A
CENTER CONTACT	BRASS PER ASTM-B-16, HALF HARD	GOLD PLATE PER MIL-G-45204

UNLESS OTHERWISE SPECIFIED DIMENSIONS ARE IN INCHES	DRAWN BY D.CAM	DATE 7/14/78	 AMP Incorporated 140 Fourth Avenue Waltham, MA 02451-7599
FRAC. ± 1/64	DEC. ± .005	ANGLES ± °	
CHECKED BY S.W.M. 7/20/78 APP'D BY R.M.F. 7/25/78			
THESE DRAWINGS AND SPECIFICATIONS ARE THE PROPERTY OF M/A CDM INTERCONNECT DIV. AND SHALL NOT BE REPRODUCED OR COPIED OR USED IN WHOLE OR IN PART AS THE BASIS FOR THE MANUFACTURE OR SALE OF ITEMS WITHOUT WRITTEN PERMISSION.		USE ASSY PROCEDURE NO. A.P. N/A	TITLE 7MM PRECISION ADAPTER "OSN" JACK SIZE B CODE IDENT NO. 26805 SCALE 2:1
		7082-5004-00	REV 03 ₁ SHEET 1 OF 1

- NOTES:
1. CAPTURED CENTER CONTACT
 2. FREQUENCY: DC-18.0 GHz
 3. VSWR (MAX): 1.008 ±.002f GHz

$$\frac{.XXX}{XX.X} = \frac{\text{in}}{\text{mm}}$$

CUSTOMER DRAWING
 AMP PART # 1061757-1
 SHEET 1 OF 1 REV B