

REVISIONS			
REV	DESCRIPTION	DATE	APPROVED
02 _z	REDRAWN ON CAD ECN 94-0474	2/6/95	<i>[Signature]</i>

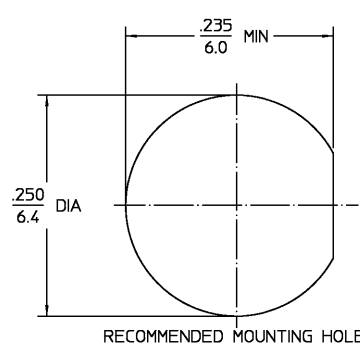

COMPONENT	MATERIAL	FINISH
HOUSING MOUNTING NUT	STAINLESS STEEL PER ASTM-A484 AND ASTM-A582, TYPE 303	GOLD PLATE PER MIL-G-45204
DIELECTRIC	TFE FLUOROCARBON PER ASTM-D-1457	N/A
CENTER CONTACT	BERYLLIUM COPPER PER ASTM-B-196 OR ASTM-B-197, ALLOY C17300, CONDITION H	GOLD PLATE PER MIL-G-45204
GASKET	VITON 'A' PER MIL-R-83248	N/A

NOTES:
1. CAPTURED CENTER CONTACT

UNLESS OTHERWISE SPECIFIED DIMENSIONS ARE IN INCHES FRAC. ± 1/64 DEC. ± .005 ANGLES ± °	DRAWN BY	DATE	AMP Incorporated 140 Fourth Avenue Waltham, MA 02451-7599
	CHECKED BY		
These drawings and specifications are the property of M/A CDM Interconnect Div. and shall not be reproduced or copied or used in whole or in part as the basis for the manufacture or sale of (item) without written permission.	APPD BY		AMP TITLE OSSM BULKHEAD JACK TO JACK ADAPTER-HERMETICALLY SEALED SIZE B CODE IDENT NO. 1084-1100-00 SCALE 10/1 REV 02 _z SHEET 1 OF 1
	USE ASSY PROCEDURE		
	NO. AP.	N/A	

CUSTOMER DRAWING AMP PART # 1045725-1 SHEET 1 OF 1 REV A