

DRAWING MADE IN THIRD ANGLE PROJECTION

THIS DRAWING IS UNPUBLISHED. RELEASED FOR PUBLICATION
 © COPYRIGHT 19 BY AMP INCORPORATED, HARRISBURG, PA. ALL INTERNATIONAL RIGHTS RESERVED. AMP PRODUCTS MAY BE COVERED BY U.S. AND FOREIGN PATENTS AND/OR PATENTS PENDING.

LOC	DIST	P	F	ZONE	LTR	DESCRIPTION	DATE	APPROVED
AJ	16				G	REV PER 0514-0177-02	20FEB03	JGH

- 1 BERYLLIUM COPPER PER ASTM-B-196
- 2 STAINLESS STEEL PER ASTM-A-582
- 3 PTFE PER ASTM-D-1710
- 4 STEEL WIRE PER QQ-W-470
- 5 BRASS PER ASTM-B-16
- 6 GOLD PL PER MIL-G-45204
- 7 PASSIVATION PER QQ-P-35
- 8 NICKEL PL PER QQ-N-290
- 9 .190 MAX PANEL THICKNESS
- 10 .060 MAX FLOAT PERMITTED DUE TO INTERNAL SPRING
- 11 BOILLAT B05 PER UNS 53800

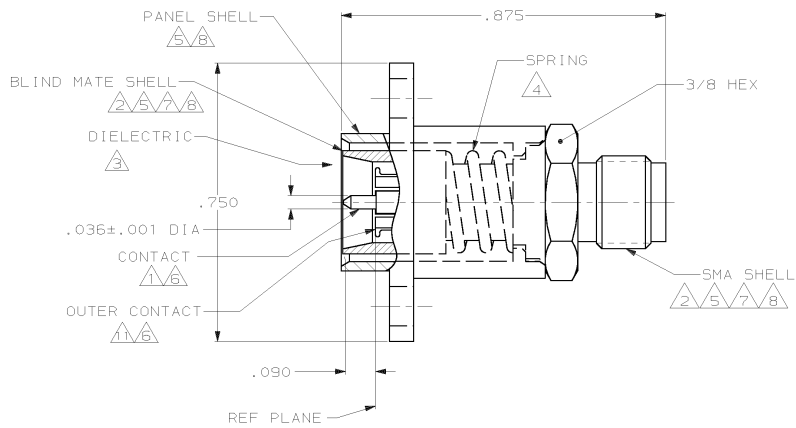

SUP5D BY 448091-2	448091-2	448091-1
SMA SHELL MAT'L/FINISH	PART NUMBER	

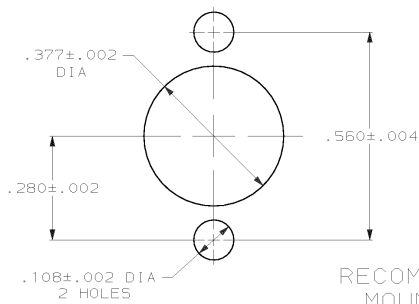

RECOMMENDED MOUNTING HOLES

UNLESS OTHERWISE SPECIFIED DIMENSIONS ARE IN INCHES TOLERANCES ON : 2 PL DEC ± 3 PL DEC ± .005 ANGLES ±		DR S. BURKHOLDER 14MAY98	PART NO	
MATERIAL	THRU	CHK J. HAVENER 14MAY98	AMP INCORPORATED Harrisburg, Pa. 17105	
FINISH	THRU	APPD S. BURKHOLDER 14MAY98	NAME ADAPTER, PLUG, FLOATING, 3.5MM BLIND MATE, TO JACK, SMA	
PRODUCT SPEC		APPD J. HAVENER 14MAY98	SIZE C	FSCM NO 00779
APPLICATION SPEC		WEIGHT	DRAWING NO 448091	SHEET 1 OF 1
SCALE 5:1		CUSTOMER DRAWING		