

4

3

2

1

THIS DRAWING IS UNPUBLISHED. RELEASED FOR PUBLICATION
 © COPYRIGHT - BY TYCO ELECTRONICS CORPORATION. ALL INTERNATIONAL RIGHTS RESERVED.

LOC		DIST		REVISIONS			
P	LTR	DESCRIPTION		DATE	DWN	APVD	
B		REV PER ECO-10-020184		10JAN2011	RG	DO	

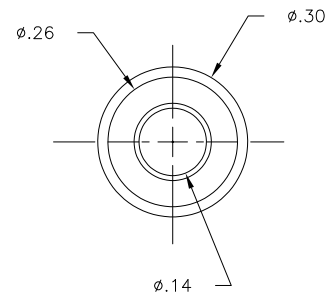
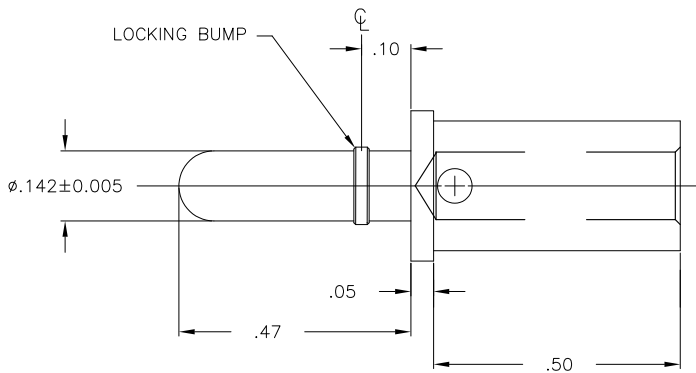

- TOOLING REQUIRED FOR CRIMP CONTACTS SIZE #8 & #10:
 CRIMP TOOL PART No. M22520/23-01
 CRIMP DIE ASSEMBLY PART No. M22520/23-02
 LOCATOR PART No. M22520/23-09

4. FINISHES: SILVER PLATED

3. MATERIAL: TELLURIUM COPPER

- ITEMS PROVIDED TO THIS SPECIFICATION TO BE IDENTIFIED ON THE CONTAINER WITH THE FOLLOWING INFORMATION: PART NUMBER AND DATE CODE OF MANUFACTURE.

- PART NUMBER CHANGES AND/OR DESIGN CHANGES AFFECTING ITEM INTERCHANGEABILITY REQUIRE PRIOR ELCON APPROVAL AND AUTHORIZATION BY REVISION TO THIS DRAWING.

1766161-1
PART NUMBER

THIS DRAWING IS A CONTROLLED DOCUMENT.		DWN	10JAN2011	Tyco Electronics Corporation	
		CHK	10JAN2011	Harrisburg, PA 17105-3608	
DIMENSIONS:		D. ORRIS		NAME	
INCHES		D. ORRIS		PIN CONTACT SIZE No.8	
		APVD		SIZE No.10 CRIMP BARREL	
		PRODUCT SPEC		LOCKING ICCON	
		APPLICATION SPEC		SIZE	RESTRICTED TO
				A3	
MATERIAL		WEIGHT		CAGE CODE	DRAWING NO
				00779	1766161
FINISH		CUSTOMER DRAWING		SCALE	SHEET
				5:1	1 of 1
				REV	B