

NUMBER C-1775227
 METRIC
 3RD ANGLE PROJECTION

THIS INFORMATION IS CONFIDENTIAL AND IS RELEASED TO YOU ON CONDITION THAT NO FURTHER DISCLOSURE IS MADE BY YOU TO OTHER THAN AMP PERSONNEL WITHOUT DIMENSIONS IN MILLIMETERS. DO NOT SCALE PRINT.

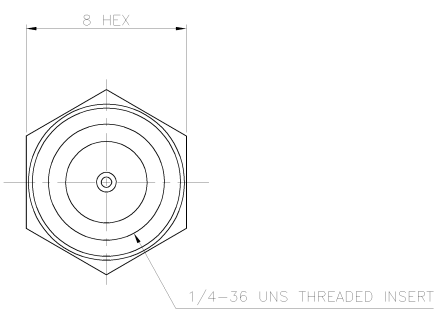
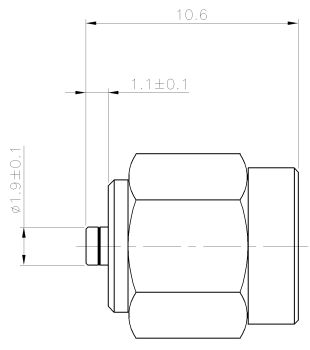

- NOTE:
- MATERIAL:
 SMA BODY: BRASS.
 MC PLUG: BRASS.
 CENTER CONTACT: BRASS.
 INSULATOR: TEFLON, UL 94V-0, WHITE COLOR.
 C-RING: STAINLESS STEEL.
 GASKET: SILICON RUBBER, ORANGE COLOR.
 - FINISH:
 0.03302µm [1.3µ"] MIN. GOLD PLATED OVER 1.27µm [50µ"] MIN. NICKEL ON SMA BODY, MC PLUG & CENTER CONTACT.

PRINT	DIST				
DW					
	A	FIRST RELEASED	--	AW	15 JUN 2006
	LTR	REVISION RECORD	ECN	DWS	CHK

TOLERANCES UNLESS OTHERWISE SPECIFIED:	DWN	A. WU	tyco TYCO HOLDINGS (BERMUDA) VII LTD. TAIWAN BRANCH			
0 PLC ±	15-JUN-2006	S. HOU	NAME			
1 PLC ±0.3		15-JUN-2006	SMA CONVERSION ADAPTOR			
2 PLC ±0.2			UMCC TYPE II/III (AMC-113)			
3 PLC ±0.1			SCALE			
ANGLES ±5°			SHEET			
MATERIAL	APVD	W.J. KE	LOC	SIZE	DRAWING NO	REV
SEE NOTE	15-JUN-2006		DW	A ₃	C-1775227	A
FINISH	QUALIFICATION TEST REPORT		SCALE			
SEE NOTE						
	WEIGHT	2.4 GRAMS				

1775227-1
 PART NUMBER

CUSTOMER DRAWING 1

NUMBER C-1775227
 METRIC
 3RD ANGLE PROJECTION

THIS INFORMATION IS CONFIDENTIAL AND IS DECLASSIFIED TO YOU ON CONDITION THAT NO FURTHER DISCLOSURE IS MADE BY YOU TO OTHER THAN AMP PERSONNEL WITHOUT DIMENSIONS IN MILLIMETERS. DO NOT SCALE PRINT.

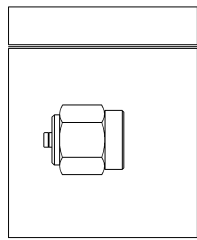

INNER BAG
 50 X 50 X 0.04

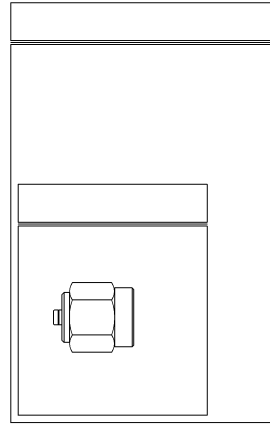

OUTER BAG
 70 X 100 X 0.04

28.9 g	24.3 g	1	10	10 PCS
GROSS WEIGHT	NET WEIGHT	PCS /INNER BAG	INNER BAGS /OUTER BAG	QUANTITY

TOLERANCES UNLESS OTHERWISE SPECIFIED:	DWN	A. WU	tyco TYCO HOLDINGS (BERMUDA)	
0 PLC ±	15-JUN-2006	15-JUN-2006	VII LTD. TAIWAN BRANCH	
1 PLC ±		S. HOU	Electronics	
2 PLC ±		15-JUN-2006	NAME	
3 PLC ±			SMA CONVERSION ADAPTOR	
ANGLES ±			UMCC TYPE II/III (AMC-113)	
MATERIAL	APVD	W.J. KE	LOC	SIZE
-	15-JUN-2006	15-JUN-2006	DW	A ₃
FINISH	APPLICATION SPEC		DRAWING NO	REV
-			C-1775227	A
WEIGHT			SCALE	SHEET
-			--	2 OF 2

LTR	SEE SHEET 1.	ECN	DWN/CHK	DATE
	REVISION RECORD			

CUSTOMER DRAWING