

REV.	DATE	DESCRIPTION
A	06/05/03	UPDATE DRAWING FORMAT
B	01/31/06	ADD GASKET DETAIL AND X-SECTION

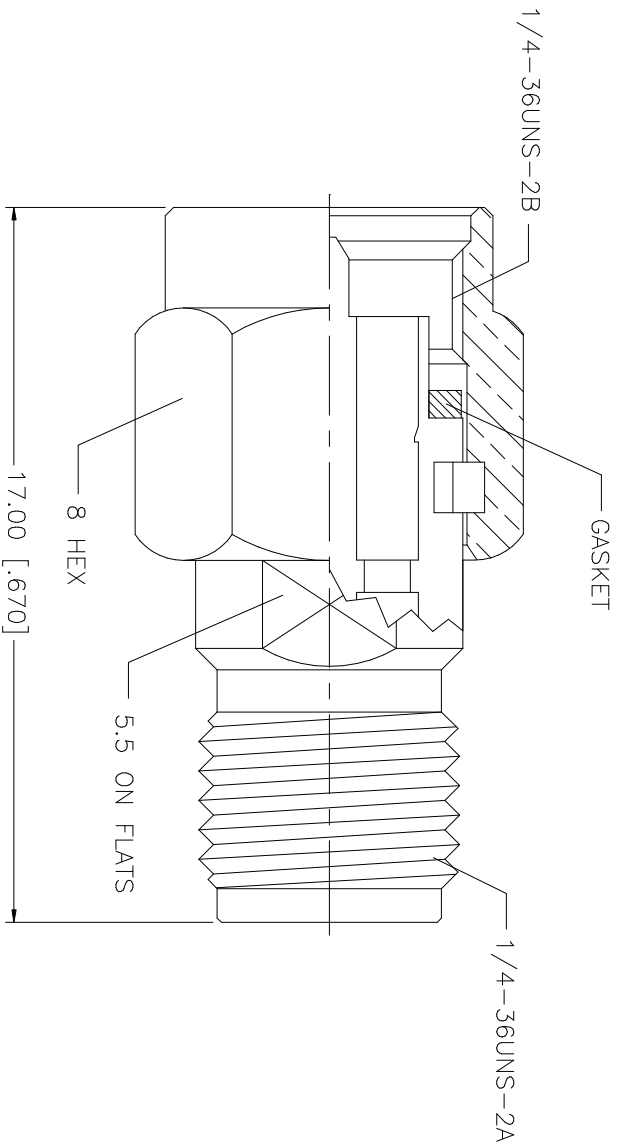

QTY	FINISH	MATERIAL	DESCRIPTION
1	RED	SILICONE	GASKET
1	GOLD	BER. COPPER	CONTACT PIN
1	NATURAL	TEFLON	INSULATOR
1	GOLD	BRASS	BODY/SHELL
			DESCRIPTION

APPROVALS	DATE
DRAWN G.R.S.	01/31/06
CHECKED	
ISSUED	
SHEET 1 OF 1	

PART DESCRIPTION	PART NO.
SMA MALE TO FEMALE ADAPTER	132171

UNLESS OTHERWISE SPECIFIED DIMENSIONS ARE IN INCHES AND FOR CUSTOMER REFERENCE ONLY.	UNLESS OTHERWISE SPECIFIED DIMENSIONS ARE IN MILLIMETERS AND FOR CUSTOMER REFERENCE ONLY.
TOLERANCES FOR MILLIMETERS ARE: 0.5 - 8mm ± 0.20mm 8 - 30mm ± 0.40mm 30 - 120mm ± 0.50mm	TOLERANCES FOR INCHES ARE: .020 - .315 = ± 0.007" .315 - 1.180 = ± 0.015" 1.180 - 4.724 = ± 0.020"

DO NOT SCALE DRAWING	CAD FILE	DWG. NO.	REV.	SIZE	SCALE
	C:/132/132171.DWG	132171.DWG	B	A	NA

Amphenol Connex

SMA MALE TO FEMALE ADAPTER

132171