

REVISIONS			
REV	DESCRIPTION	DATE	APPROVED
01 ₂	REVISED	7/22/96	[Signature] 7/26/96

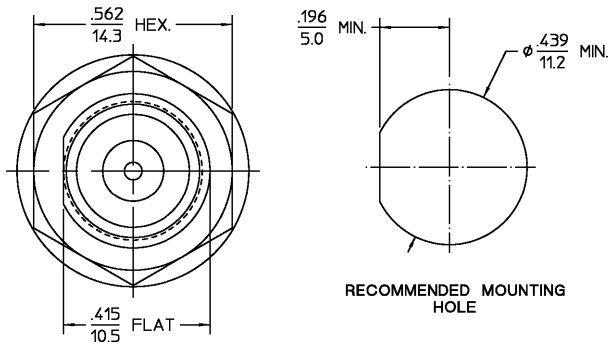

COMPONENT	MATERIAL	FINISH
HOUSING NUT MOUNTING NUT LOCKWASHER	STAINLESS STEEL PER ASTM-A484 AND ASTM- A582, TYPE 303	PASSIVATE PER QQ-P-35
DIELECTRIC	TFE FLUOROCARBON PER ASTM-D-1457	N/A
CENTER CONTACT	BERYLLIUM COPPER PER ASTM-B-196 OR ASTM-B-197, ALLOY C17300, CONDITION H	GOLD PLATE PER MIL-G-45204
GASKET	SILICONE RUBBER PER ZZ-R-765	N/A

UNLESS OTHERWISE SPECIFIED DIMENSIONS ARE IN INCHES FRAC. ± 1/64 DEC. ± .005 ANGLES ± °	DRAWN BY S. W. A.	DATE 11/8/84	AMP Incorporated 140 Fourth Avenue Waltham, MA 02451-7599	
	CHECKED BY H. L. B.	11/16/84		
These drawings and specifications are the property of M/A CDM Interconnect Div. and shall not be reproduced or copied or used in whole or in part as the basis for the manufacture or sale of (item) without written permission.	USE ASSY PROCEDURE		TITLE *OST* JACK TO *OSM* JACK ADAPTER BULKHEAD FEEDTHRU	
	NO. AP. N/A	SIZE B		CODE IDENT NO. 26805
		SCALE 4:1		3184-2240-00
			REV 01 ₂ SHEET 1 OF 1	

NOTES:
1. CAPTURED CENTER CONTACT

.XXX = in
XX.X = mm (REF)

CUSTOMER DRAWING

TYCO P/N 1057908-1
SHEET 1 OF 1, REV 0