

NUMBER C-1775229
 METRIC
 3RD ANGLE PROJECTION

PRINT DW
 THIS INFORMATION IS CONFIDENTIAL AND IS DECLASSIFIED TO YOU ON CONDITION THAT NO FURTHER DISCLOSURE IS MADE BY YOU TO OTHER THAN AMP PERSONNEL WITHOUT DIMENSIONS IN MILLIMETERS. DO NOT SCALE PRINT.

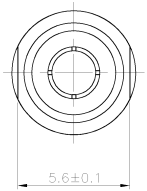
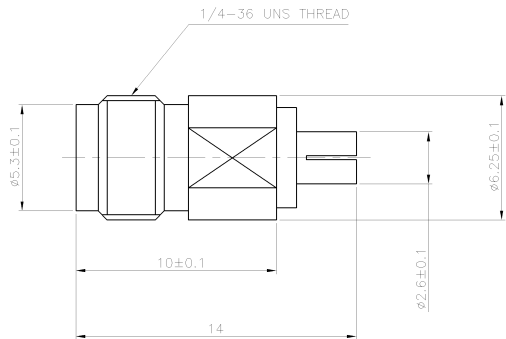

NOTE:

1. MATERIAL:
 SMA BODY: BRASS.
 CENTER CONTACT: BRASS.
 GROUND CONTACT: BRASS.
 INSULATOR: TEFLON, UL 94V-0, WHITE COLOR.
2. FINISH:
 0.03302μm [1.3μ"] MIN. GOLD PLATED OVER 1.27μm [50μ"] MIN. NICKEL ON SMA BODY & CENTER CONTACT.
 3.81μm [150μ"] MIN. SILVER PLATED OVER 1.27μm [50μ"] MIN. NICKEL ON GROUND CONTACT.

A	FIRST RELEASED	--	AW	SH	15JUN 2006
LTR	REVISION RECORD	ECN	DWS	CHK	DATE

TOLERANCES UNLESS OTHERWISE SPECIFIED: 0 PLC ± 1 PLC ±0.3 2 PLC ±0.2 3 PLC ±0.1 ANGLES ±5°	DWN	A. WU 15-JUN-2006	tyco TYCO HOLDINGS (BERMUDA) VII LTD. TAIWAN BRANCH NAME			
	CHK	S. HOU 15-JUN-2006				
	MATERIAL SEE NOTE	APVD	W.J. KE 15-JUN-2006	SMA CONVERSION ADAPTOR UMCC TYPE I (AMC-921)		
FINISH SEE NOTE	QUALIFICATION TEST REPORT	-	LOC	SIZE	DRAWING NO	REV
	WEIGHT	1.55 GRAMS	DW	A ₃	C-1775229	A
			SCALE	SHEET		
				--		1 OF 2

1775229-1
 PART NUMBER

CUSTOMER DRAWING 1

NUMBER C-1775229

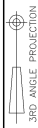

METRIC

THIS INFORMATION IS CONFIDENTIAL AND IS RELEASED TO YOU ON CONDITION THAT NO FURTHER DISCLOSURE IS MADE BY YOU TO OTHER THAN AMP PERSONNEL WITHOUT DIMENSIONS IN MILLIMETERS. DO NOT SCALE PRINT.

PRINT DIST DW

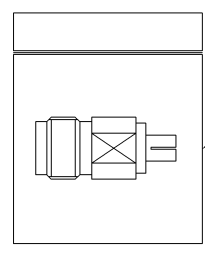

INNER BAG
50 X 50 X 0.04

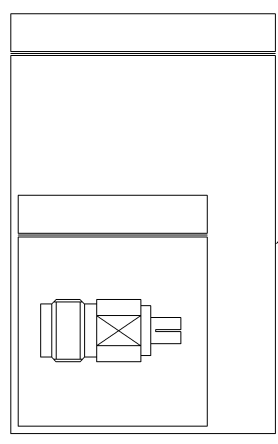
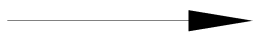

OUTER BAG
70 X 100 X 0.04

LTR	SEE SHEET 1.	ECN	DWN/CHK	DATE
	REVISION RECORD			

20.3 g	15.7 g	1	10	10 PCS
GROSS WEIGHT	NET WEIGHT	PCS /INNER BAG	INNER BAGS /OUTER BAG	QUANTITY

TOLERANCES UNLESS OTHERWISE SPECIFIED:	DWN	A. WU	tyco TYCO HOLDINGS (BERMUDA)			
0 PLC ±		15-JUN-2006	VII LTD. TAIWAN BRANCH			
1 PLC ±	CHK	S. HOU	Electronics			
2 PLC ±		15-JUN-2006	NAME			
3 PLC ±						
ANGLES ±						
MATERIAL	APVD	W.J. KE	SMA CONVERSION ADAPTOR UMCC TYPE I (AMC-921)			
-		15-JUN-2006				
FINISH	APPLICATION SPEC		LOC	SIZE	DRAWING NO	REV
-			DW	A ₃	C-1775229	A
	WEIGHT		SCALE		SHEET	
			--		2 OF 2	

CUSTOMER DRAWING