

DRAWING MADE IN THIRD ANGLE PROJECTION

THIS DRAWING IS UNPUBLISHED. RELEASED FOR PUBLICATION, 19 .

© COPYRIGHT 19 BY AMP INCORPORATED. ALL INTERNATIONAL RIGHTS RESERVED.

LOC	DIST	REVISIONS				
P	F	ZONE	LTR	DESCRIPTION	DATE	APPD
AJ	16		A	REVISED PER EC 0220-0099-96	08FEB96	MEC

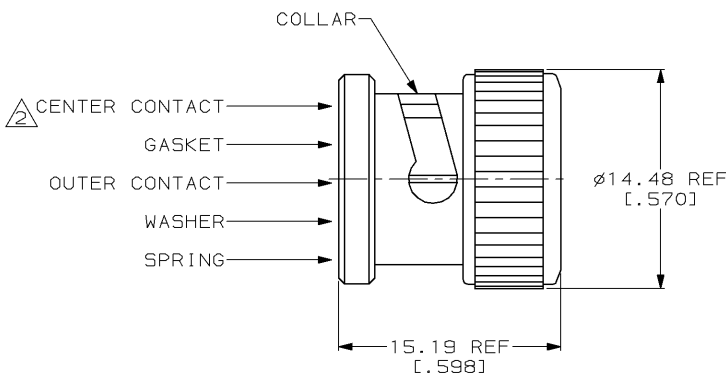

- MATERIALS:  
 SPRING - CARBON STEEL (SK-5)  
 CENTER CONTACT - BRASS  
 COLLAR - BRASS  
 OUTER CONTACT - BRASS  
 WASHER - BRASS  
 GASKET - SILICONE RUBBER
- GOLD PLATE PER MIL-G-45204,  
 0.76μm [.000030] MIN THICKNESS
- NICKEL PLATE PER QQ-N-290,  
 2.54μm [.000100] MIN THICKNESS

413453-1  
 PART NUMBER  
 PART NO

DO NOT SCALE PRINT. UNLESS SPECIFIED DIMENSIONS IN INCHES TOLERANCES ON: 2 PLC DEC ± - 3 PLC DEC ± - ANGLES ± -	DR	J. L. GROFT	5-1-89	<b>AMP</b> AMP INCORPORATED Harrisburg, Pa. 17105
	CHK	D. LAMAN	5-2-89	
	APPD	M. PHILLIPS	5-3-89	
	APPD	D. LAMAN	5-3-89	
MATERIAL	SEE NOTES	PRODUCT SPEC		NAME PLUG, SHORTING CAP, BNC
FINISH	SEE NOTES	APPLICATION SPEC		SIZE <b>B</b>
		WEIGHT	-	FSCM NO 00779
				DRAWING NO 413453
				SCALE 4:1
				SHEET 1 OF 1

AMP 1470-15 REV 3-87  
 01 MAY 1989 13:26:10 603419 407140:DEPT1427:6031541.0424-02

CUSTOMER DRAWING