

REV.	DATE	DESCRIPTION
NC	02/05/07	INITIAL RELEASE

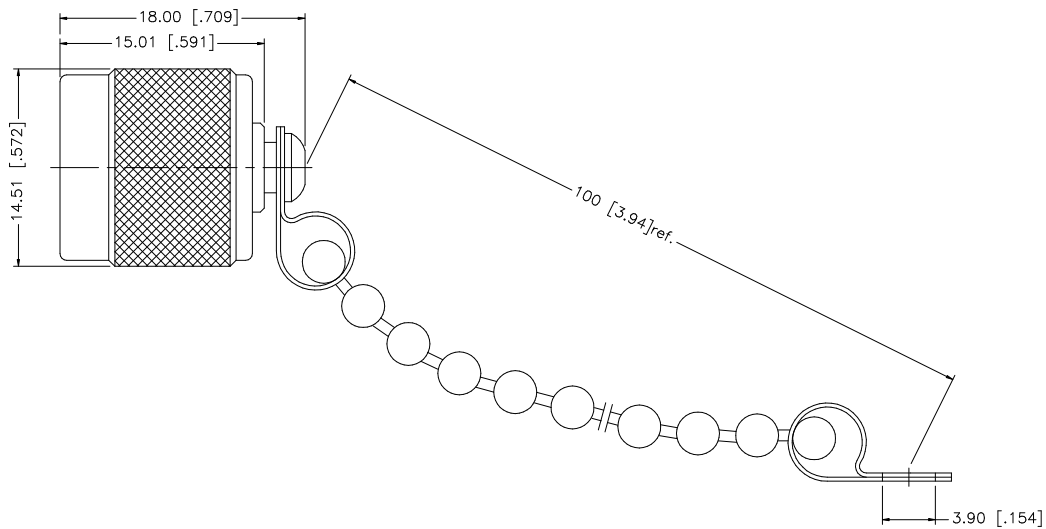

8					UNLESS OTHERWISE SPECIFIED DIMENSIONS ARE IN MILLIMETERS. DIMENSIONS IN [ ] ARE IN INCHES AND FOR CUSTOMER REFERENCE ONLY.	APPROVALS	DATE	<b>Amphenol Connex</b>		
7					UNLESS OTHERWISE SPECIFIED TOLERANCES FOR MILLIMETERS ARE: 0.5 - 8mm ± 0.20mm 8 - 30mm ± 0.40mm 30 - 120mm ± 0.50mm	DRAWN G.R.S.	02/05/07			
6					UNLESS OTHERWISE SPECIFIED TOLERANCES FOR INCHES ARE: .020 - .315 = ± 0.007" .315 - 1.180 = ± 0.015" 1.180 - 4.724 = ± 0.020"	CHECKED		PART NO. <b>202101</b>		
5						ISSUED				
4	RIVET	BRASS	NICKEL	1		SHEET 1 OF 1		REV. NC	SIZE A	SCALE NA
3	CHAIN	BRASS	NICKEL	1						
2	GASKET	SILICONE	RED	1						
1	SHELL/BODY	BRASS	NICKEL	1						
	DESCRIPTION	MATERIAL	FINISH	QTY	DO NOT SCALE DRAWING	CAD FILE C:/202/202101.DWG				