

4

3

2

1

THIS DRAWING IS UNPUBLISHED. RELEASED FOR PUBLICATION SEP25 1995
 © COPYRIGHT 1995 BY AMP INCORPORATED. ALL RIGHTS RESERVED.

LOC	QTY	REVISIONS			
P	LTR	DESCRIPTION	DATE	DWN	APVD
		E	REV PER 0G30-0163-98	03JUN98	MO BM
		F	REV PER 0U20-0040-99	02AUG99	MO BM

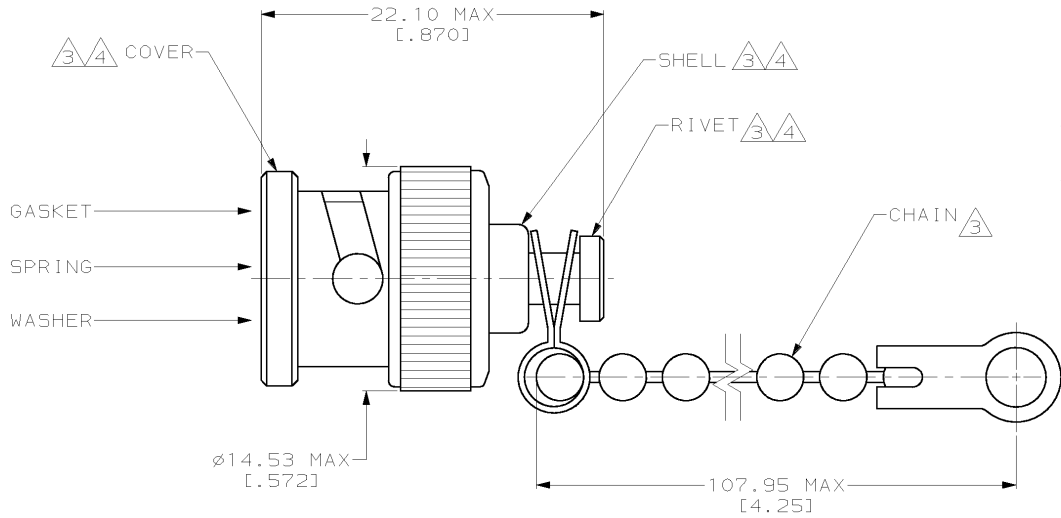

- MATERIALS:
 SHELL - BRASS
 GASKET - SILICONE RUBBER
 WASHER - BRASS
 CHAIN - BRASS
 RIVET - BRASS
 SPRING - SPRING STEEL
 COVER - BRASS
 3 NICKEL PLATE PER QQ-N-290, 2.54µm [.000100] MIN THICKNESS
 4 SILVER PLATE PER QQ-5-365, 5.08µm [.000200] MIN THICKNESS
- CHAIN IS AVAILABLE IN NICKEL PLATING ONLY.

3	1-330022-2
4	330022
FINISH	PART NUMBER

<small>THIS DRAWING IS A CONTROLLED DOCUMENT FOR AMP INCORPORATED. IT IS SUBJECT TO CHANGE AND THE CONTROLLING ENGINEERING ORGANIZATION SHOULD BE CONTACTED FOR THE LATEST REVISION.</small>		DWG MICHAEL E. COWHER 27SEP95 CHK FRANK MORANA 27SEP95 APVD FRANK MORANA 27SEP95	AMP AMP Incorporated Harrisburg, PA 17105-3608
DIMENSIONS: mm [INCHES] 0 PLC ±.01 1 PLC ±.02 2 PLC ±.03 3 PLC ±.04 4 PLC ±.05 ANGLES ±.01 FINISH SEE NOTES	TOLERANCES UNLESS OTHERWISE SPECIFIED: ±.01 ±.02 ±.03 ±.04 ±.05 ±.06 ±.07 ±.08 ±.09 ±.10 ±.15 ±.20 ±.25 ±.30 ±.35 ±.40 ±.45 ±.50 ±.60 ±.70 ±.80 ±.90 ±1.00 ±1.50 ±2.00 ±3.00 ±4.00 ±5.00 ±6.00 ±7.00 ±8.00 ±9.00 ±10.00	PRODUCT SPEC APPLICATION SPEC WEIGHT - CUSTOMER DRAWING	NAME COVER, JACK, BNC SIZE A3 CAGE CODE 00779 DRAWING NO C-330022 SCALE 4:1 SHEET 1 OF 1 REV F