

FEATURES:

- These SMB (Subminiature “B”) connectors snap together for quick assembly
- Connector meets interface requirements of MIL-C-39012

MATERIALS:

Body and Fittings – Brass per QQ-B-626, Alloy 360, ½ Hard

Center Contact – Brass per QQ-B-626, Alloy 360, ½ Hard

Dielectric – PTFE

Finish:

Body and Fittings – Tarnish resistant

Center Contact – Gold plated per requirements of MIL-C-39012

Marking: “POMONA 5379” located approximately as shown

RATINGS:

Operating Temperature: -65°C (-85°F) to +165°C (+329°F)

Impedance: 50 Ohms

Frequency Range: DC to 4GHz

All dimensions are in inches. Tolerances (except noted): .xx = ±.02” (.51 mm), .xxx = ± .005” (.127 mm).

All specifications are to the latest revisions. Specifications are subject to change without notice.

Registered trademarks are the property of their respective companies.

Made in USA

6/9/99

SY/EH/LS

S:\Engineering\Release\DataSheets\FI\ukeDataSheet\AI_5379_2_01.doc

Sales: 800-490-2361 Fax: 888-403-3360

Technical Assistance: 800-241-2060

PomonaACCESS 90122 (800) 444-6785 or (425) 446-6010

More drawings available at www.pomonaelectronics.com

Page 1 of 2

ORDERING INFORMATION: Model 5379

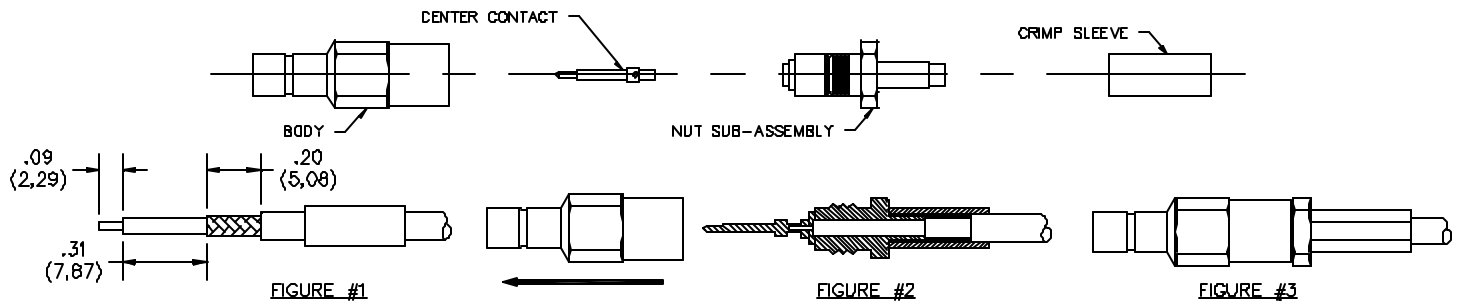

FIGURE #1

- A. Slide crimp sleeve over cable.
- B. Strip cable to dimensions shown.

FIGURE #2

- C. Slightly rotate dielectric of cable to free braid, install nut sub-assembly onto cable. Slit cable jacket if necessary.
- D. Push crimp sleeve against nut sub-assembly and crimp (.128 Hex).
- E. Solder contact to center conductor.
- F. Thread nut sub-assembly onto body, tighten securely

FIGURE #3

- G. Completed assembly shown.

All dimensions are in inches. Tolerances (except noted): .xx = ±.02" (.51 mm), .xxx = ±.005" (.127 mm).
All specifications are to the latest revisions. Specifications are subject to change without notice.
Registered trademarks are the property of their respective companies.

Made in USA

6/9/99

SY/EH/LS

S:\Engineering\Release\DataSheets\FI\IkeDataSheet\AI_5379_2_01.doc

Sales: 800-490-2361 Fax: 888-403-3360

Technical Assistance: 800-241-2060

PomonaACCESS 90122 (800) 444-6785 or (425) 446-6010

More drawings available at www.pomonaelectronics.com

Page 2 of 2