

REV.	DATE
NC	08/01/05

DESCRIPTION  
INITIAL RELEASE

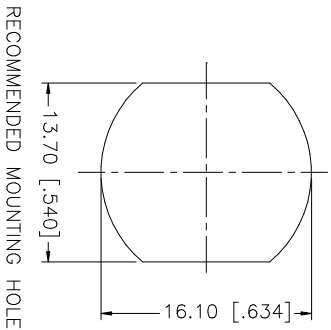

RECOMMENDED MOUNTING HOLE

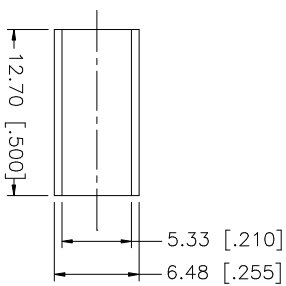
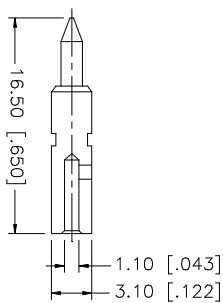
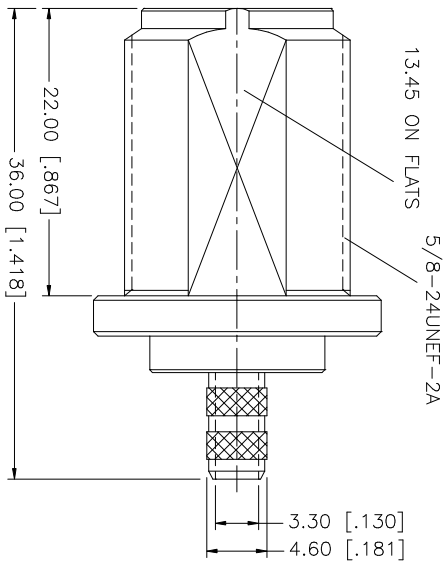
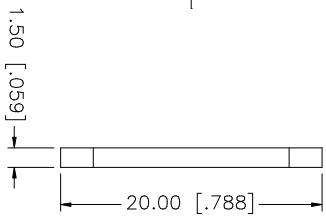
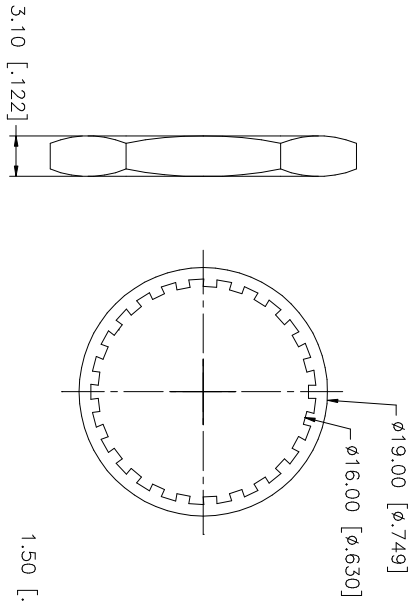
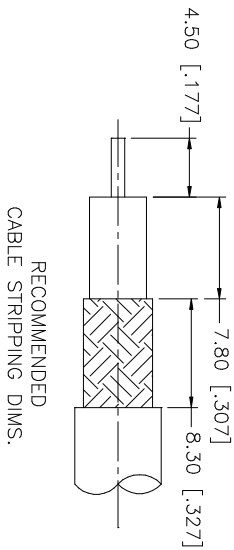

RECOMMENDED  
CABLE STRIPPING DIMS.

- NOTE:
1. CRIMPED FERRULE  
HEX CRIMP SIZE .213"
  2. CRIMPED CONTACT PIN  
HEX CRIMP SIZE .105"

QTY	FINISH	MATERIAL	DESCRIPTION
1	NEXCOTE	COPPER	FERRULE
1	NEXCOTE	BRASS	HEX NUT
1	NEXCOTE	BRASS	LOCK WASHER
1	RED	SILICONE	GASKET
1	GOLD	BRASS	CONTACT PIN
1	NATURAL	TEFLON	INSULATOR
1	NEXCOTE	BRASS	BODY

UNLESS OTHERWISE SPECIFIED DIMENSIONS ARE IN MILLIMETERS. DIMENSIONS IN [ ] ARE IN INCHES AND FOR CUSTOMER REFERENCE ONLY.	UNLESS OTHERWISE SPECIFIED TOLERANCES FOR MILLIMETERS ARE:	UNLESS OTHERWISE SPECIFIED TOLERANCES FOR INCHES ARE:
0.5 - 8mm ± 0.20mm	8 - 30mm ± 0.40mm	30 - 120mm ± 0.50mm
UNLESS OTHERWISE SPECIFIED TOLERANCES FOR INCHES ARE:		
.020 - .315 = ± 0.007"	.315 - 1.180 = ± 0.015"	1.180 - 4.724 = ± 0.020"

APPROVALS	DATE
DRAWN G.R.S.	08/01/05
CHECKED	
ISSUED	
SHEET 1 OF 1	

PART NO.	PART DESCRIPTION
172106RP	N REVERSE POLARITY BULKHEAD CRIMP JACK (FOR RG-58 CABLE)

CAD FILE	DWG. NO.	REV.	NC	SIZE	SCALE
C:/172/172106RP.DWG	172106RP.DWG		NC	A	NA

**Amphenol Connex**

N REVERSE POLARITY BULKHEAD CRIMP JACK  
(FOR RG-58 CABLE)

172106RP