

THIS DRAWING IS UNPUBLISHED. RELEASED FOR PUBLICATION
 © COPYRIGHT BY TYCO ELECTRONICS CORPORATION. ALL INTERNATIONAL RIGHTS RESERVED.

LOC	DIST	REVISIONS			
P	LTR	DESCRIPTION	DATE	OWN	APVD
A		REV PER ECO 08-021971	20NOV08	PK	WM

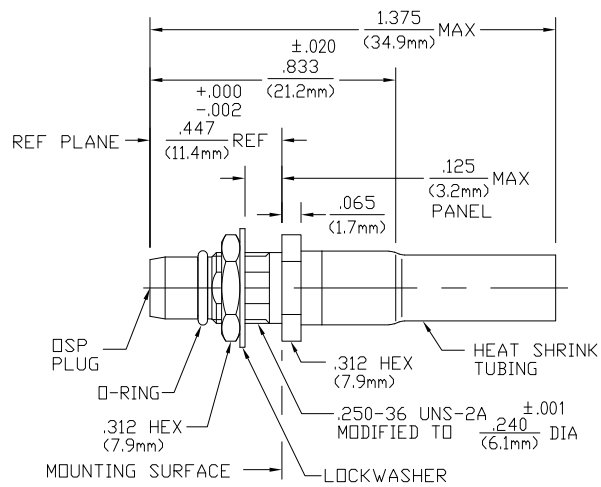

DESIGNED FOR USE WITH RG 142/U & SIMILAR CABLES CABLE ENTRY DIAMETER MINIMUM	
HOUSING	.122
FERRULE	.216
CONTACT	.042

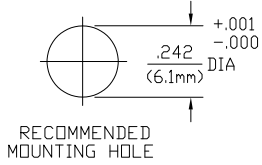

COMPONENT	MATERIAL	FINISH
HOUSING MOUNTING NUT LOCKWASHER	STAINLESS STEEL PER ASTM-A484 AND ASTM-A582, TYPE 303	PASSIVATE PER ASTM-A380
DIELECTRIC	TFE FLUOROCARBON PER ASTM-D-1457	N/A
CENTER CONTACT	BERYLLIUM COPPER PER ASTM B 196, ALLOY C17300, CONDITION H	GOLD PLATE PER MIL-G-45204 OVER COPPER PLATE PER MIL-C-14550
"O" - RING	NITRILE (BUNA-N) PER MIL-P-25732	N/A
SHRINK TUBING	HEAT SHRINKABLE POLYOLEFIN COMPOUND MIL-I-23053/4	N/A
FERRULE	COPPER OR BRASS ALLOY ROCKWELL F65 MAXIMUM	GOLD PLATE PER MIL-G-45204 OVER COPPER PLATE PER MIL-C-14550

ELECTRICAL	MECHANICAL	ENVIRONMENTAL
Nominal Impedance (Ohms) <u>50</u>	Interface Dimensions Per MIL-STD-348A FIG 321-1	TEMPERATURE RATING -65° TO +125°C
Frequency Range (GHz) DC to 12.4	Force to Engage (In-Lbs MAX) <u>3.0</u> & Disengage (In-Lbs MAX) <u>1.5</u>	Vibration MIL-STD-202, Method 204, Condition D
Volt Rating (VRMS MAX) @ Sea Level <u>335</u>	Center Contact Captivation	Shock MIL-STD-202, Method 213, Condition I
VSWR <u>1.15+0.1F(GHz)</u> DC to 12.4 GHz	Axial (Lbs) <u>6.0</u>	Thermal Shock MIL-STD-202, Method 107, Condition B
Insertion Loss (dB MAX) <u>.03x V(FGHz)</u>	Cable Retention	Except High Temp Shall Be +115°C
RF Leakage (dB MIN) (Fully Mated) -(85-f(GHz))	Axial Force (Lbs MIN) <u>45.0</u>	Moisture Resistance MIL-STD-202, Method 106, Except Step 7b Shall Be Omitted
Corona, 70,000 Ft (VRMS MIN) <u>250</u>	Weight (Grams) <u>TBD</u>	Corrosion - MIL-STD-202, Method 101, Condition B
Dielectric Withstanding Voltage (VRMS MIN) @ Sea Level <u>1000</u>		
Contact Resistance (Milliohms MAX)		
Center Contact <u>3.0</u>		
Outer Contact <u>2.0</u>		
Cable to Housing <u>0.5</u>		
RF High Potential @ Sea Level (VRMS MIN @ 5 MHz) <u>670</u>		
I.R.(Megohms MIN) <u>5000</u>		

THIS DRAWING IS A CONTROLLED DOCUMENT.		DWN MH/M 11-5-87	Tyco Electronics Corporation Harrisburg, PA 17105-3608	
DIMENSIONS: INCHES		CHK MH/M 11-5-87	NAME	
TOLERANCES UNLESS OTHERWISE SPECIFIED:		APVD D. CAM 11-5-87	OSP BULKHEAD FEEDTHROUGH CABLE PLUG - CRIMP ATTACHMENT	
0 PLC ± -	1 PLC ± -	PRODUCT SPEC	SIZE	CAGE CODE
2 PLC ± -	3 PLC ± .005	APPLICATION SPEC	A300779	1059519
4 PLC ± -	ANGLES ± 1°	WEIGHT	DRAWING NO	RESTRICTED TO
MATERIAL SEE TABLE	FINISH SEE TABLE	CUSTOMER DRAWING	A300779	©=1059519
		SCALE 3:1	SHEET 1 of 1	REV A