

4

3

2

1

THIS DRAWING IS UNPUBLISHED. RELEASED FOR PUBLICATION. ALL RIGHTS RESERVED. BY TYCO ELECTRONICS CORPORATION. COPYRIGHT

LOC	DIST	REVISIONS			
DF	X5	P	LWR	DATE	MIN
		L	REV PER ECO 06-01723	1-23-06	CT
					BM

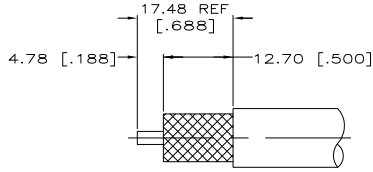

VIEW X
RECOMMENDED STRIP LENGTH

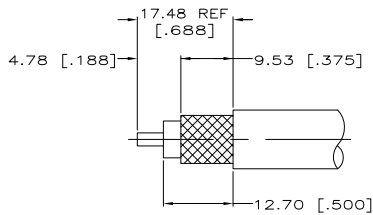

VIEW Y
RECOMMENDED STRIP LENGTH

- 1. PARTS PACKAGED UNASSEMBLED.
- △ THREE SAFETY WIRE HOLES Ø0.61 [.024] MINIMUM, EQUALLY SPACED AROUND CIRCUMFERENCE.
- 3. SEE INSTRUCTION SHEET #2028-5.
- △ OBSOLETE PART NUMBER.
- △ SUPERSEDED BY 225389-4.

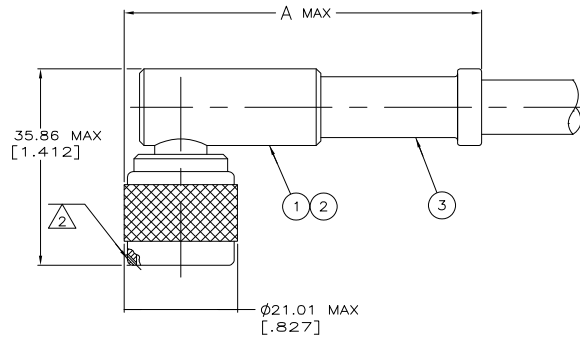

									△ 7-225389-4
RG-213/U	7-225389-2 AMP	220015-1	62.31 [2.453]	Y	1-331987-3	51704-2	225417-1		7-225389-2
RG-225/U	5-225389-3 TYCO	220015-1	62.31 [2.453]	X	1883158-1	1-51704-0	1883152-1		5-225389-3
MICRODOT 250-4172 & 250-4208	225389-9 AMP	220015-3	61.49 [2.421]	Y	225612-2	51704-2	225904-1		1-225389-0
RG-165/U & M15224	225389-8 AMP	220015-1	62.31 [2.453]	Y	1-331987-3	1-51704-0	225417-1		225389-8
RG-393/U	225389-6 AMP	220015-1	62.31 [2.453]	X	225490-1	1-51704-0	225417-1		225389-6
RG-214/U	10688467 AMP	220015-1	62.31 [2.453]	X	331987	51704-2	225417-1		225389-5
RG-214/U	00779 M39012/05B0003 AMP & DATE CODE	220015-1	62.31 [2.453]	X	331987	51704-2	225417-1		225389-4
RG-225/U	225389-3 AMP	220015-1	62.31 [2.453]	X	331987	1-51704-0	225417-1		225389-3
RG-213/U	00779 M39012/05B0002 AMP & DATE CODE	220015-1	62.31 [2.453]	Y	1-331987-3	51704-2	225417-1		225389-2
RG-115A/U	225389-1 AMP	220015-1	62.31 [2.453]	X	1-331987-3	51704-2	225417-2		225389-1
CABLE SIZE	STAMPING	CRIMP TOOL	A	VIEW	③ FERRULE QTY=1	② CONTACT QTY=1	① PLUG ASSY QTY=1		PART NUMBER

THIS DRAWING IS A CONTROLLED DOCUMENT. DATE: 10-30-91

BY: B. SCOTT DATE: 9-20-91
 CHK: M. SNEED DATE: 10-30-91
 M. SNEED DATE: 10-31-91

INCHES: 0 PLC ± .01
 1 PLC ± .015
 2 PLC ± .02
 3 PLC ± .025
 4 PLC ± .03

TOLERANCES UNLESS OTHERWISE SPECIFIED.

MATERIAL: _____ FINISH: _____

WEIGHT: 2.6 OZ MAX

CUSTOMER DRAWING

TYCO ELECTRONICS CORPORATION
 HARRISBURG, PA 17105-3608

PLUG, RIGHT ANGLE, WEATHERPROOF, SERIES N

SIZE: A2 CASE CODE: C DRAWING NO: 00779 C-225389

RESTRICTED TO: _____

SCALE: 2:1 SHEET: 1 of 1 REV: L