

4

3

2

1

THIS DRAWING IS UNPUBLISHED. RELEASED FOR PUBLICATION  
 © COPYRIGHT - BY TYCO ELECTRONICS CORPORATION. ALL RIGHTS RESERVED.

LOC	DIST	REVISIONS			
P	LTR	DESCRIPTION	DATE	DWN	APVD
	A1	REVISED PER ECO-10-006951	02APR10	HMR	WK

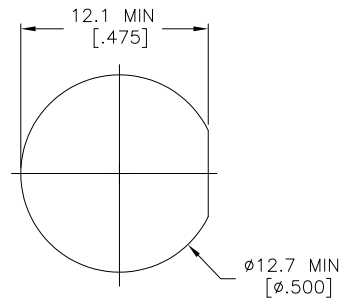
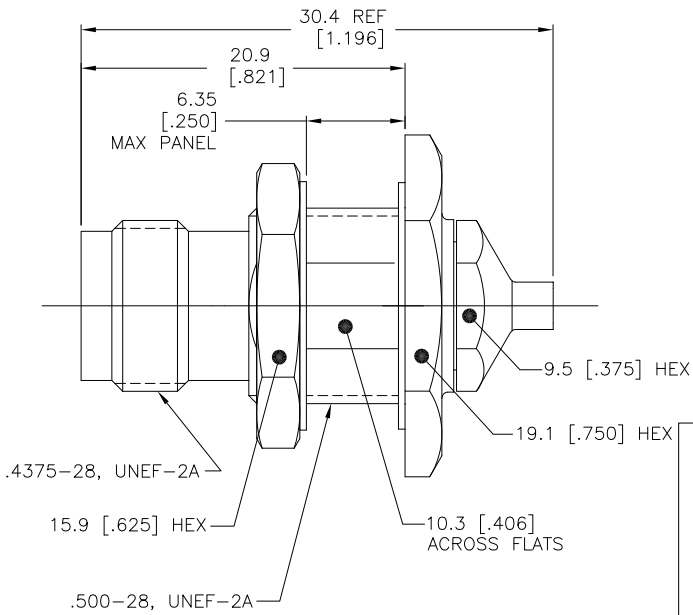

RECOMMENDED MOUNTING HOLE

1. SEE INSTRUCTION SHEET 408-8205.

REAR HOUSING  
MOUNTING NUT  
LOCKWASHERSTAINLESS STEEL PER ASTM-A484 AND  
ASTM-A582PASSIVATE PER  
QQ-P-35

FRONT HOUSING

BRASS PER ASTM-B-16

GOLD PLATE PER  
ASTM-B488

DIELECTRIC

TFE FLUOROCARBON PER ASTM-D-1710

N/A

CENTER  
CONTACTBERYLLIUM COPPER PER ASTM-B-196  
OR  
ASTM-B-197GOLD PLATE PER  
ASTM-B488

N/A

GASKET

SILICONE RUBBER PER ZZ-R-765

COMPONENT

MATERIAL

FINISH

DESIGNED FOR USE WITH .141" S.R.	
CABLE ENTRY DIAMETER MINIMUM	
HOUSING	3.61 [.142]
CONTACT	1.07 [.042]

THIS DRAWING IS A CONTROLLED DOCUMENT.

DIMENSIONS:	TOLERANCES UNLESS OTHERWISE SPECIFIED:
mm [INCHES]	
0 PLC	± -
1 PLC	± 0.13 [.005]
2 PLC	± -
3 PLC	± -
4 PLC	± -
ANGLES	± 1°
MATERIAL	FINISH
-	-

DWN	R.M.K.	3/5/70
CHK	B.W.C.	6/29/70
APVD	T.A.R.	6/29/70
PRODUCT SPEC	-	-
APPLICATION SPEC	-	-
WEIGHT	-	-
CUSTOMER DRAWING		

Tyco Electronics Corporation Harrisburg, PA 17105-3608	
NAME TNC STRAIGHT BULKHEAD CABLE JACK DIRECT SOLDER VERSION	
SIZE	CAGE CODE DRAWING NO
A3	00779 C-1057676
RESTRICTED TO	-
SCALE	4:1
SHEET	1 OF 1
REV	A1