

4

3

2

1

THIS DRAWING IS UNPUBLISHED. RELEASED FOR PUBLICATION
 © COPYRIGHT - BY TYCO ELECTRONICS CORPORATION. ALL RIGHTS RESERVED.

LOC	DIST	REVISIONS				
P	LTR	DESCRIPTION	DATE	DWN	APVD	
	AJ	16				
J		REVISED PER EC OS14-0173-05	26JULY05	BM	JL	

1. FOR USE WITH: BELDEN 8281, WE 724 & 3049 CABLES.
2. CRIMPING TOOL: 69652
3. SEE INSTRUCTION SHEET 408-1799-1.

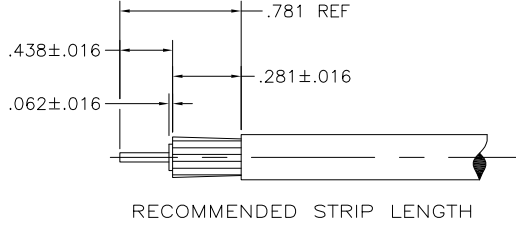
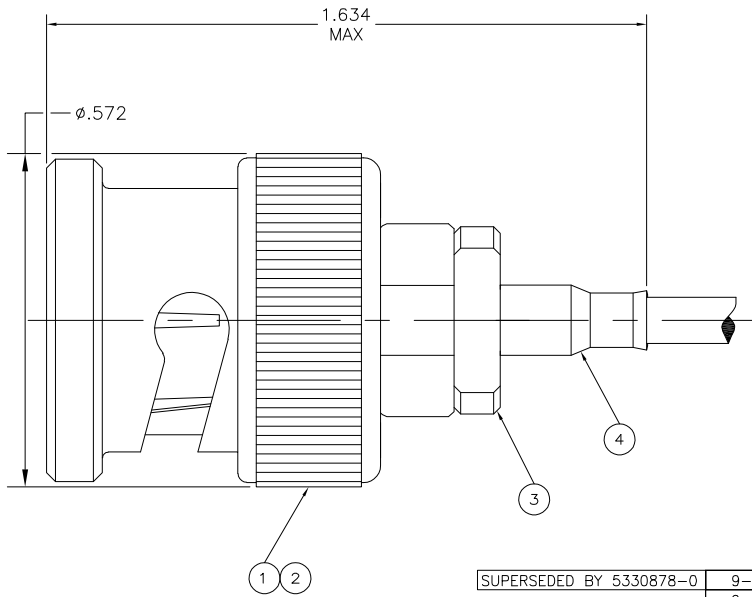

SUPERSEDED BY 5330878-0	9-331256-0	1-50780-7	2-329106-1	9-329327-0	9-330878-0
	9-331256-0	1-50780-7	2-329106-1	329327	330878
4 FERRULE QTY=1	3 CRIMP END QTY=1	2 GASKET QTY=1	1 PLUG ASSEMBLY QTY=1	PART NUMBER	

THIS DRAWING IS A CONTROLLED DOCUMENT.		DWN M. E.	05-24-83	 Tyco Electronics Corporation Harrisburg, Pa 17105-3608	
DIMENSIONS: INCHES		CHK D. HEIDE	08-26-83		
TOLERANCES UNLESS OTHERWISE SPECIFIED:		APVD G. M.	12-09-83		
0 PLC ± -	1 PLC ± -	PRODUCT SPEC	NAME	CONNECTOR, COAXIAL RF PLUG, SERIES BNC	
2 PLC ± -	3 PLC ± -	APPLICATION SPEC	SIZE CAGE CODE DRAWING NO		
4 PLC ± -	ANGLES ± -	WEIGHT .458 OZ	A300779 C-330878	RESTRICTED TO	
MATERIAL	FINISH	CUSTOMER DRAWING	SCALE NTS	SHEET 1 OF 1	REV J

AMP 1470-19 REV 31MAR2000