

4

3

2

1

THIS DRAWING IS UNPUBLISHED. RELEASED FOR PUBLICATION
 © COPYRIGHT - By - ALL RIGHTS RESERVED.

LOC		DIST		REVISIONS			
P	LTR	DESCRIPTION		DATE	DWN	APVD	
F1		REVISED PER ECO-11-005030		11MAR11	RK	HMR	

1. FOR USE WITH: RG-55A/U & 58C/U CABLE
2. CRIMP WITH TOOL: 220061-1
3. SEE I.S. 2322
4. 00779 M39012/55B3021

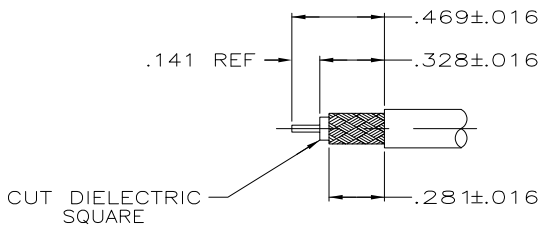
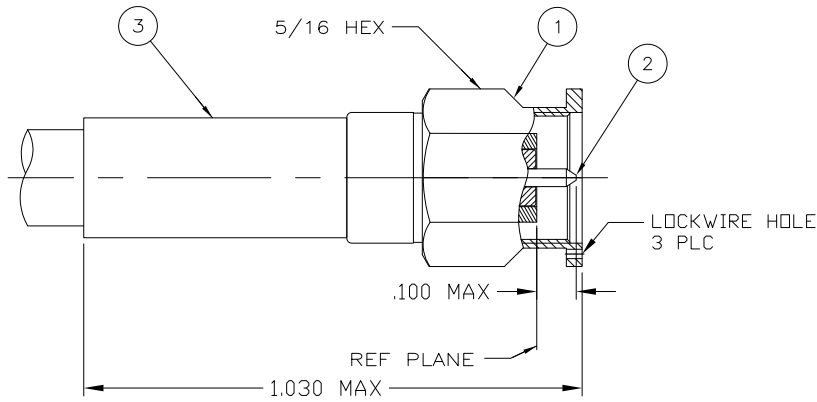

RECOMMENDED STRIP LENGTH
 SCALE: 2:1

1	225619-2	FERRULE	3
1	225540-2	CONTACT	2
1	225533-1	PLUG ASSEMBLY	1
QTY	PART NUMBER	DESCRIPTION	ITEM

THIS DRAWING IS A CONTROLLED DOCUMENT.		DWN L.A.MOSCOSO 8-17-88		
DIMENSIONS: INCHES		CHK M.SNEED 9-12-88		
TOLERANCES UNLESS OTHERWISE SPECIFIED:		APVD	NAME PLUG, SERIES SMA	
0 PLC ± -		PRODUCT SPEC	SIZE	
1 PLC ± -		APPLICATION SPEC	CAGE CODE	DRAWING NO
2 PLC ± -		WEIGHT	RESTRICTED TO	
3 PLC ± -		.141 OZ	A3	00779
4 PLC ± -		CUSTOMER DRAWING	©	225532-1
ANGLES ± -		SCALE	5:1	SHEET
MATERIAL		1 OF 1		REV
FINISH		F1		